



 **TB Global Technologies Ltd.**

Notice : Tokyo Boeki Machinery Ltd. and Tokyo Boeki Engineering Ltd. merged on April 1, 2021 to become TB Global Technologies Ltd.

Head Office	28F KYOBASHI EDOGRAND, 2-2-1 Kyobashi, Chuo-ku, Tokyo, 104-0031, Japan TEL : +81-3-6841-8491 FAX : +81-3-6841-8450
Nagaoka Works	2-5-1 Jooka, Nagaoka City, Niigata, 940-0021, Japan TEL : +81-258-24-1650 FAX : +81-258-24-0000
Singapore Branch	2 Venture Drive #16-12, Vision Exchange, Singapore, 608526 TEL : +65-6909-2333 FAX : +65-6909-3474
Beijing Office	No.3 Dong San Huan Bei Lu, Chaoyang Discrit, Beijing, China 100027 Room 1014, Lucky Tower B TEL : +86-10-65516609 FAX : +86-10-65518229

<https://www.tbtech.co.jp>

Flexible 360 degree rotation

TB-NIIGATA SWIVEL JOINTS allow complicated movement of pipe line

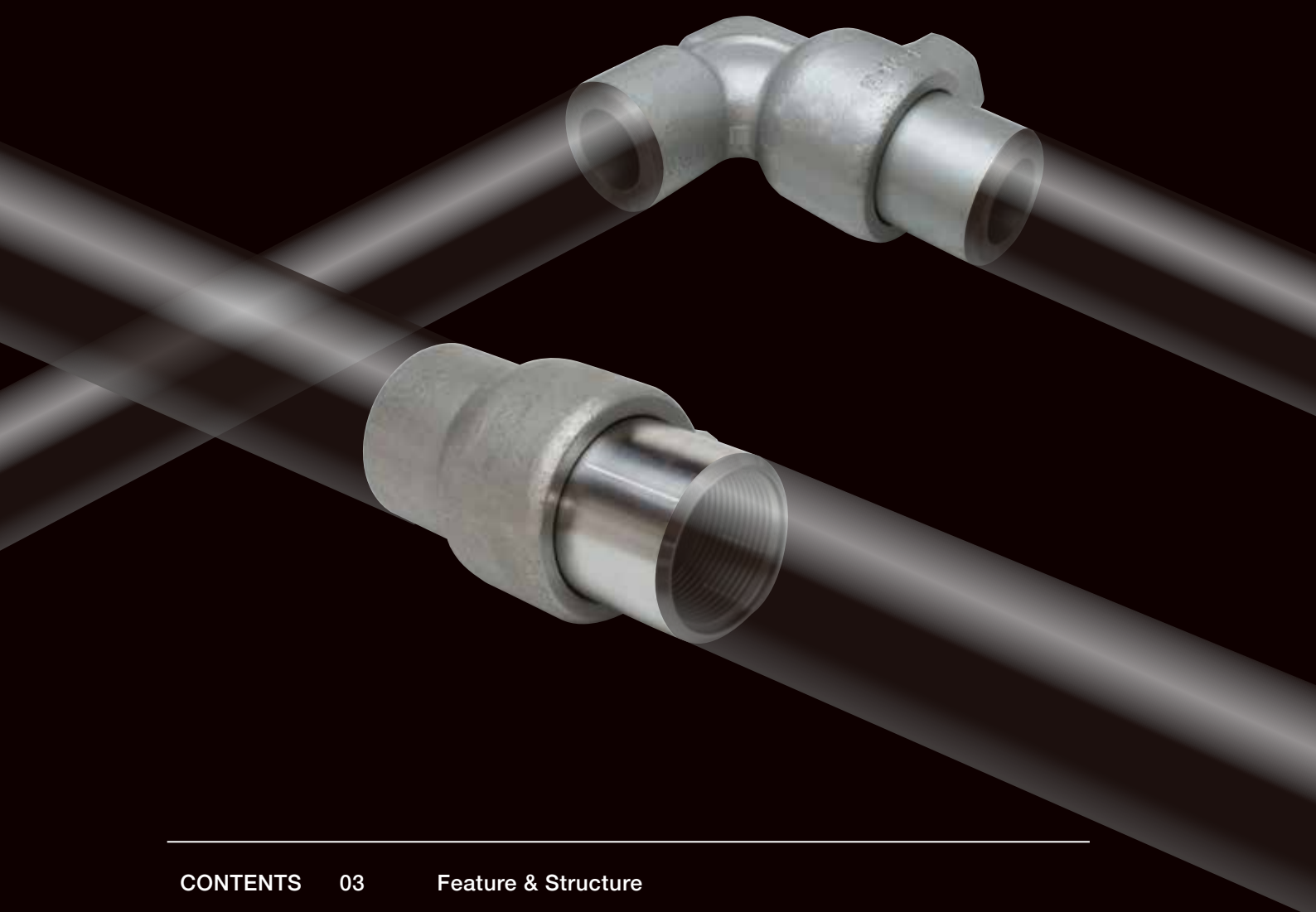

CONTENTS	03	Feature & Structure
	04	Information for spec selection
	05	Quick reference chart
	06-08	Product lineup : General-purpose type
	09	Product lineup : Double seal type(BD, BDR)
	10	Product lineup : Super high pressure balance type(NSB, NPB)
	11	Product lineup : Sanitary type(NS)
	12-21	Standard size list
	22-24	Mass list
	25-28	Replacement parts list
	29	Earthquake isolation system
	30	Articulated Piping Systems
	31-33	Precaution
	34	TB-NIIGATA Wing Union
	35	TB-NIIGATA Ball joint

TB-NIIGATA SWIVEL JOINTS



Flexible
360°
rotation

9
kinds of
standard styles

Max.
operating
pressure
34 MPa

Special packing

- Designed to reduce rotational resistance and provide high-pressure sealing with low friction.
- Offers long-lasting reliable sealing function with excellent wear resistance and low compression set.
- Features a trapezoidal cross-sectional shape to prevent twisting.
- Utilizes a self-sealing mechanism that enhances sealing performance when axial pressure is applied.
- Includes an outer ring to prevent damage from extrusion in the joint gap.

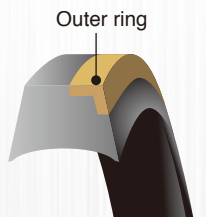

Grease retainer ring

- The unique shape of this product ensures long-lasting use with minimal wear and deformation over time.

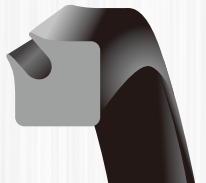

X-ring (for Submerged service)

- X-shaped cross section ensures twist-free rotation under pressure, providing durable wear resistance and sealing for internal and external pressures.
- Offers reliable sealing performance even without pressure, thanks to proper interference and a self-sealing mechanism that increases surface pressure with fluid pressure.



Ball retainer ring

- O-ring inclusion prevents dust and rainwater from entering the ball bearing area.

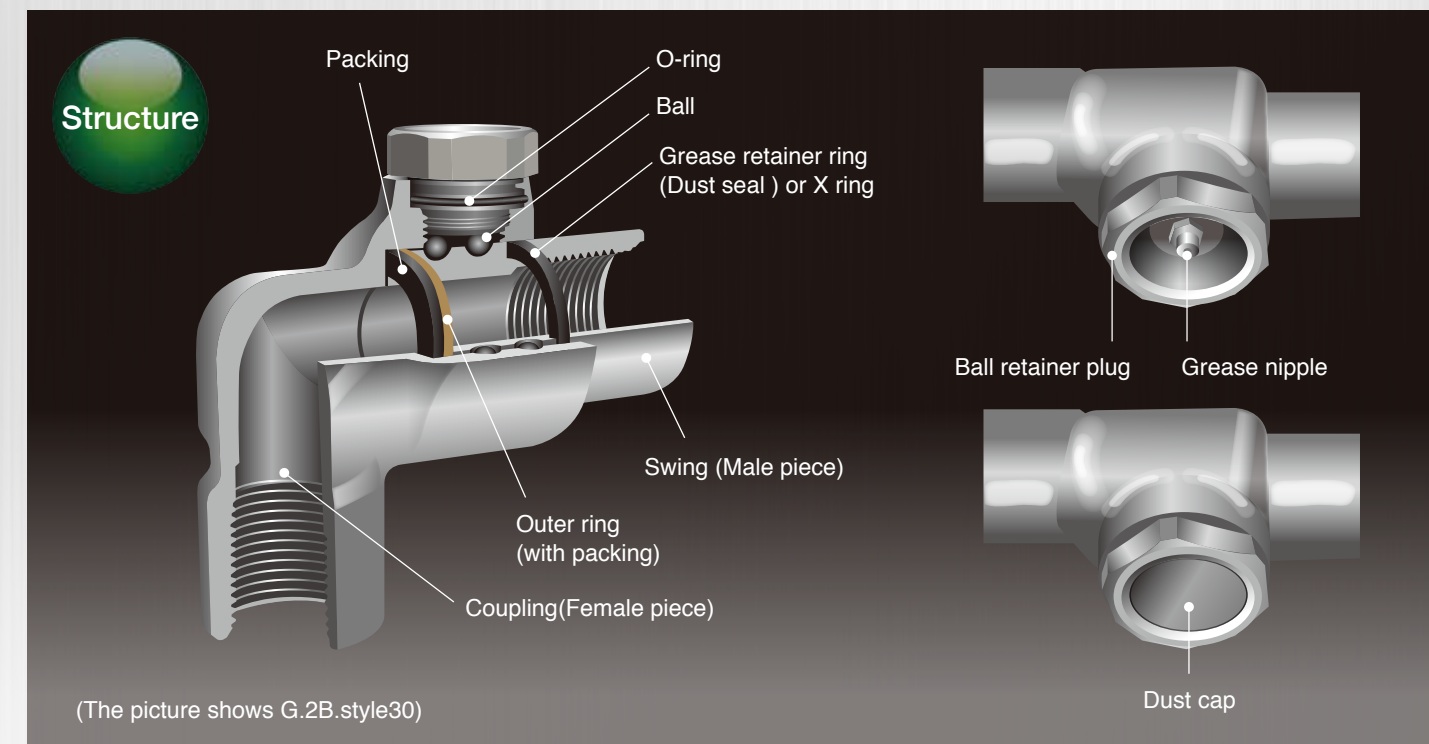

Please check the following information before order.

1 Color code 2 Size 3 Style No.

Green (G)
Blue (B)
Stainless (STT)
N style (N)
BD, BDR
Silver (S)
SN style (SN)
Orange (SH)
NHB
NSB
NPB
NSB

Nominal Dia (Inch)	
Nominal Dia	Inch
10A	3/8"
15A	1/2"
20A	4/3"
25A	1"
32A	1-1/4"
40A	1-1/2"
50A	2"
65A	2-1/2"
80A	3"
100A	4"
125A	5"
150A	6"
200A	8"
250A	10"
300A	12"

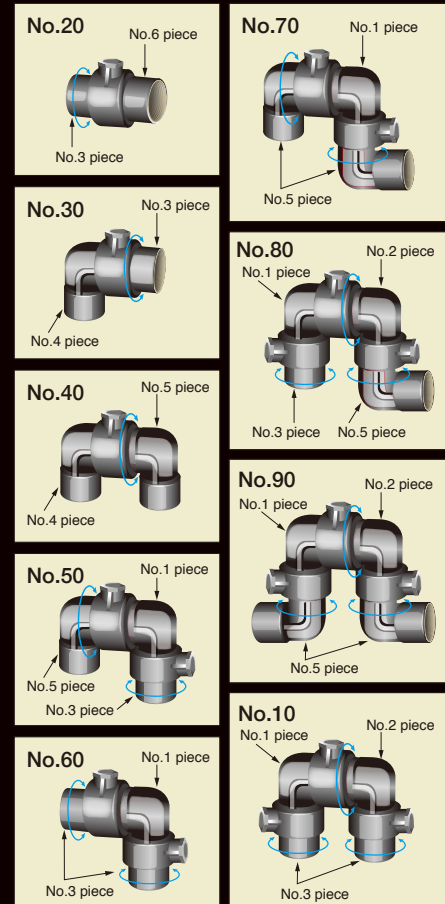

4 Packing (Seal material)

Materials	Code	Temp.Range	Main applicable fluid
NBR(Buna N)	00	-10°C~ +80°C	Industrial water, Sea water, Bunker C, Lubricant oil, Air, Cement, Hydraulic oil(water/petro), etc.NBR
NBR(Buna N Aromatic Resistance)	55	-10°C~ +60°C	Crude oil(-10 ~ +60°C), Gasoline, Jet fuel, Bunker A, LPG, CO2, etc.
EPT	6X	-35°C~ +60°C	Ammonia, etc.
FPM	HH	-7°C~ +125°C	Crude oil(+61 ~ +120°C), Hydraulic oil(ester phosphate), Sulphur acid(80 ~ 120%), etc.
PTFE + SST Spring	AD	-50°C~ +200°C	Steam, Ethyl alcohol, Chemical, Food service, etc.

5 Connection

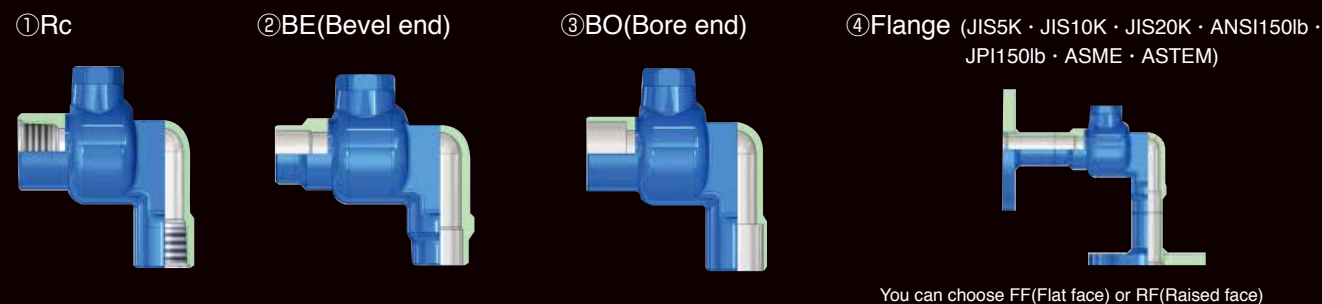

TB-NIIGATA Swivel Joint

Model	1 Color code	Material (JIS)	2 Nominal Dia (Inch)	5 End Connections			Max.Press (MPa)
				Threaded (THRD)	Flanged (FL)	Welded (WELD)	
Low Pressure	Green(G)	FCD500	3/8 ~ 4	○	-	-	2.06
	Blue(B)	S30C/S40C AISI 1040	3/8 ~ 4	○	○	○	3.43
		S40C	5 ~ 12	-	○	○	
	Stainless(SST)	SUS316	3/8 ~ 2	○	○	○	2.06
			2-1/2 ~ 4	△	○	○	
			5 ~ 12	-	○	○	
	Type N(N)	S30C	2-1/2 ~ 4	-	○	○	3.43
		SF490A	6 ~ 12	-	○	○	2.06
	BD · BDR	S40C	2-1/2 ~ 12	-	○	○	3.43
	High Pressure	Silver(S)	S40C	3/8 ~ 1	○	○	○
1-1/4 ~ 2-1/2				○	○	○	10.3
Silver(SN)		3 ~ 4		-	○	○	
Extra High Pressure	Orange(SH)	S40C	3/8 ~ 2	○	○	○	34.32
			2-1/2 ~ 5	-	○	○	20.59
Extra High Pressure Balance	NHB	S25C	1	△	○	○	37.27
	NSB	S40C	1-1/4 ~ 6	△	○	○	39.23
	NPB	S35C	3 ~ 5	-	○	○	3,4 : 25 5 : 21
Sanitary	NS	SUS316	1S ~ 4S	IDF/ISO Ferrule, Union, Plain End			0.98

※△ · · · Thread adapters are welded on the ends.
 ※Other specifications are available on a made-to-order basis.
 ※NPS · · · Normal Pipe Size

- Female thread ("Rc" in JIS) is applied to all thread connection. (especially, fluid and temperature)
- Main material of swivel joints are shown in the table above.
Material of flanges and pipes are not necessarily the same. Contact our sales representatives for more details.
- Other specifications are available upon request.



Low Pressure Swivel Joints

Green Blue

Low pressure swivel joints are used in various kinds of installations for operations. They are widely used in making up loading racks and flexible lines for handling all types of materials. The larger sizes find extensive use in all-metal loading and unloading lines, such as dock risers, and on manifold jumper lines.

Applicable Industries:

Iron, Steel, Petrochemical, Oil Refinery, Chemicals, Automobile, Machine Tools, Foods, Marine Loading / Unloading, Construction, Water / Treatment Hose Neck (prevent twist), pipe line of water or lubricant and others.

Color Code	Green (G)
Material (JIS)	FCD500
Nominal Dia.	3/8 - 4
Max. operating press.	2.06MPa
End Connection	THRD

Color Code	Blue (B)
Material (JIS)	S30C / S40C / AISI1040
Nominal Dia.	3/8 - 4 5 - 12
Max. operating press.	3.43MPa
End Connection	THRD / FL / WELD FL / WELD

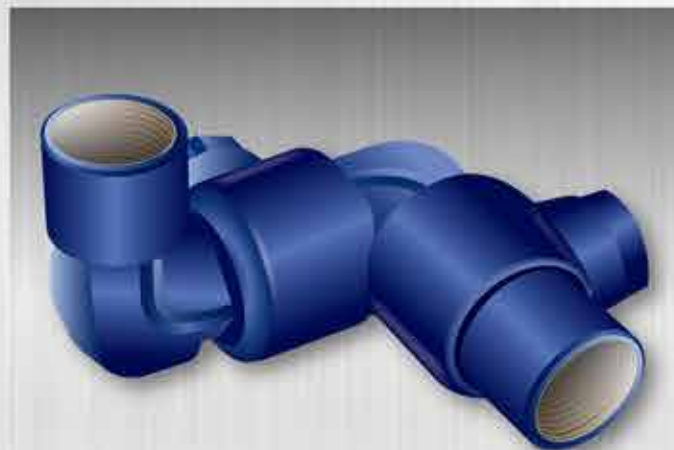

Low Pressure Swivel Joints

Stainless

Stainless steel swivel joints are mainly used for cryogenic service and corrosive substances.

Additional Option :

Snap-in ball races for resistance against heavy load

Applicable Industries:

Iron, Steel, Petrochemical, Oil Refinery, Chemicals, Foods, Marine Loading / Unloading, Water / Drainage Treatment and others.

Color Code	Stainless (SST)
Material (JIS)	SUS316
Nominal Dia.	3/8 - 4 5 - 12
Max. operating press.	2.06MPa
End Connection	THRD / FL / WELD FL / WELD



Low Pressure Swivel Joints

Type N

Type N swivel joints have a standard elbow design to minimize turbulence flow and cavitation. They are widely used in making up suction hoses, and for handling all material loading and unloading lines. Applications include dog-leg on vertical plane for gas fuel services.

Applicable Industries:

Petrochemical, Oil Refinery, Industrial machinery, many others.

Color Code	Type N (N)	
Material (JIS)	S30C	SF490A
Nominal Dia.	2-1/2 - 4	6 - 12
Max. operating press.	3.43MPa	2.06MPa
End Connection	FL / WELD	FL / WELD



High Pressure Swivel Joints

Silver (S)

High pressure swivel joints are applied to wide variety of industries as below:

They are widely used for high pressure hydraulic, air and cooling lines including others for absorption of vibration, deformation in piping system.

Applicable Industries:

Oil Drilling, Iron, Die-Cast Machine, Plastic Molding Machine, Industrial Machine, Mining, Aircraft, Various Oil Pressure Machines and Others.

Color Code	Silver	
Material (JIS)	S40C	
Nominal Dia.	3/8 - 1	1-1/4 - 2-1/2
Max. operating press.	20.59MPa	10.30MPa
End Connection	THRD / FL / WELD	



High Pressure Swivel Joints

Type SN (SN)

High pressure swivel joints are applied to wide variety of industries as below:

They are widely used for high pressure hydraulic, air and cooling lines including others for absorption of vibration, deformation in piping system.

Applicable Industries:

Oil Drilling, Iron, Die-Cast Machine, Plastic Molding Machine, Industrial Machine, Mining, Aircraft, Various Oil Pressure Machines and Others.

Color Code	Type SN (SN)
Material (JIS)	S40C
Nominal Dia.	3 - 4
Max. operating press.	10.30MPa
End Connection	FL / WELD

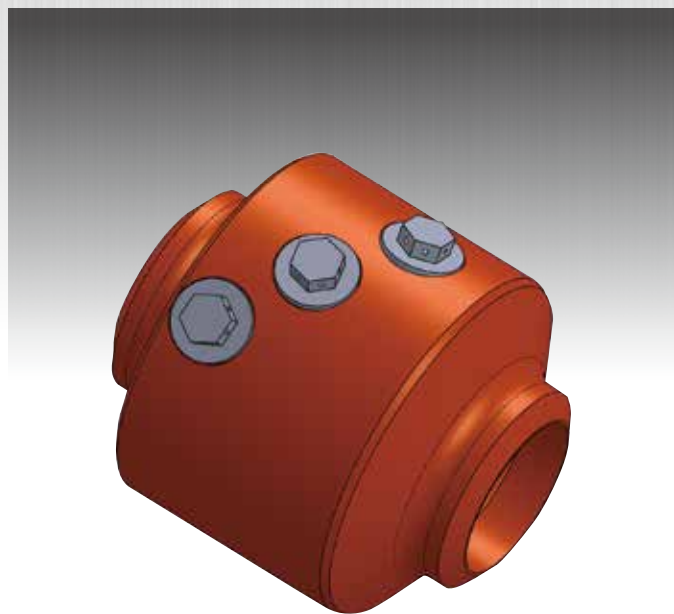

High Pressure Swivel Joints

Orange (SH)

Extra High Pressure swivel joints are designed and built for extreme heavy duty where extreme pressure and high load are encountered.

2-1/2B - 5B have triple ball race and specially designed.

Applicable Industries:

Oil Drilling, Iron, Various Industrial Machines and others.

Color Code	Orange (SH)	
Material (JIS)	S40C	
Nominal Dia.	3/8 - 2	2-1/2 - 5
Max. operating press.	34.32MPa	20.59MPa
End Connection	THRD / FL / WELD	FL / WELD

Double-seal type(BD.BDR) swivel joints are mainly used for drain piping systems for floating roof tanks. They have special double or triple-seal, structure to withstand external pressure.

Overlaid SUS316 is applied to sealing surface to prevent corrosion.

BDR was improved from BD as long service life type.



1 Double seal structure

- Added X ring for external pressure.

2 Improvement of material (Packing, O-ring)

- Improved packing and X ring material to prevent compression set.

3 Improved durability

- As a countermeasure against corrosion, overlaid SUS316 at the coupling tip end was extended.
- *During maintenance and assemble, corrosion at the coupling may cause X-rings damage.
- Added overlaid SUS316 at the lip part.
- Overlaid SUS316 at the surface of packing was extended.

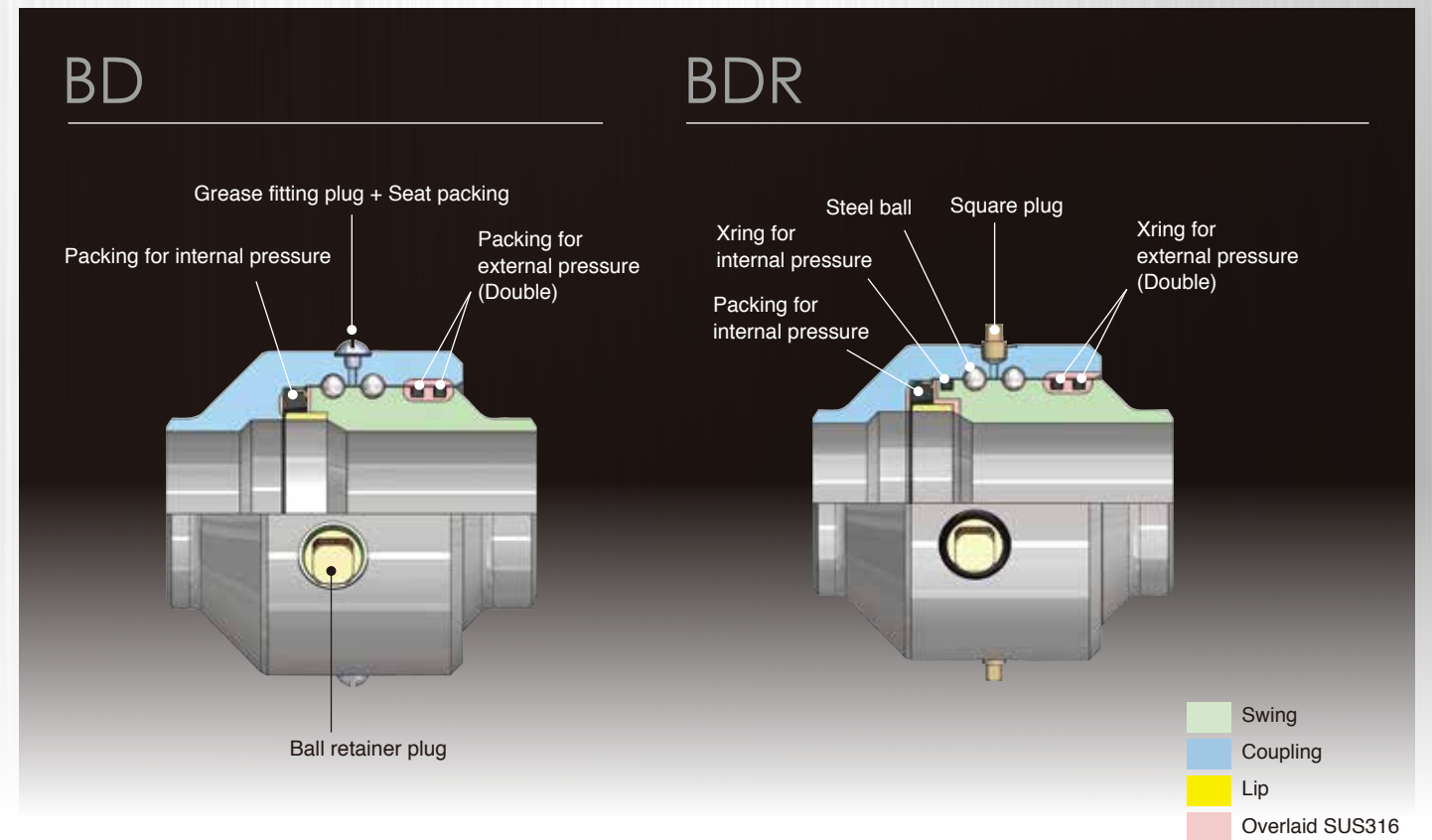

BD · BDR

Size	2-1/2 ~ 12
Max working press(internal)	3.43MPa
Max working press(external)	0.25MPa
Connection	Flange
Material	S40C

Sealing surface (Packing & Xring) : Overlaid SUS316

Detail part of ball retainer plug

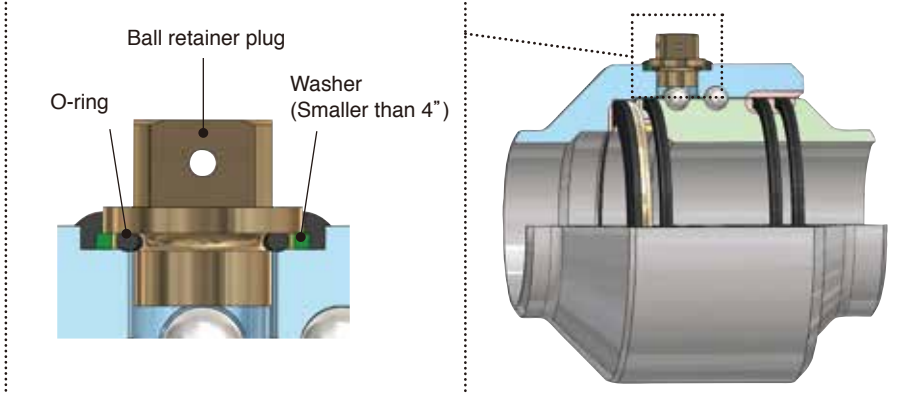

Super high pressure balanced swivel joint (NSB·NPB) SWIVEL JOINTS

NSB · NPB have pressure-balanced structure which enable them to withstand water hammer and vibration under high operating pressure.

Feature

- 1 Double seal structure (Buffer ring + O-ring) ※Only NHB·NSB
- 2 Buffer ring prevents impact pressure from being transmitted directly to the seal (O-ring B) ※Only NHB·NPB
- 3 O-ring A prevents contamination from the outside
- 4 O-ring B with backup ring of PTFE prevents the extrusion of O-ring

NSB

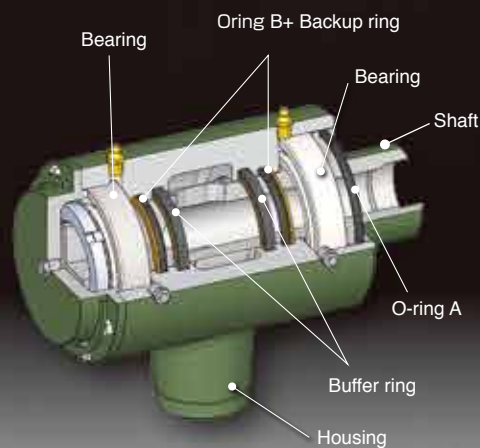

■NHB·NSB

Size	1 ~ 4(1 : NHB)
Max working press	37.27MPa(1) 39.23MPa(1-1/4 ~ 4)
Connection	Flange · Welding
Material	S40C

NPB

Weight ratio down to about 50% maximum
※Our conventional weight ratio

●Low cost · compact · short delivery time compared to NSB



■NPB

Size	3 ~ 5
Max working press	25.0MPa(3,4) 21MPa(5)
Connection	Flange · Welding
Material	S35C

■NPB · NSB Dimension table

Model	3		4	
	No.30/No.40	No.30/No.40	No.30/No.40	No.30/No.40
Dimension	NSB	NPB	NSB	NPB
A	180	112	200	130
B	145	105	180	130
C	124.5	103	148	120
D	180	166	220	218
E	256.2	188.2	301.6	231.6
F	76.2	76.2	101.6	101.6
G	89.1	89.1	114.3	114.3

No.30

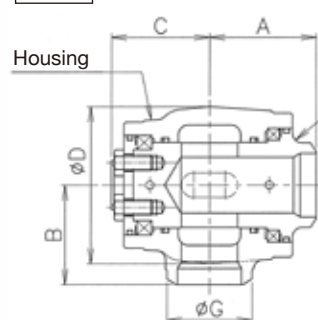

No.40

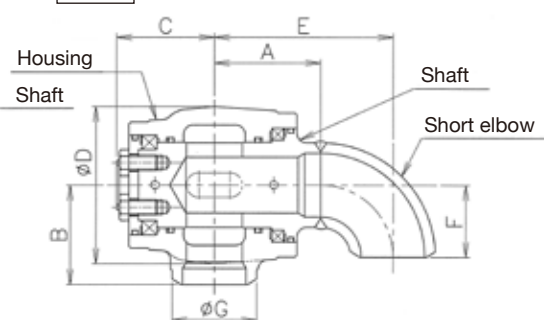

Sanitary Swivel Joints (NS) SWIVEL JOINTS

TB-NIIGATA Sanitary swivel joints are perfectly suitable for applications which have strict sanitary requirements such as food and chemical industries where frequent pipe cleaning is essential. Sanitary joints allow smooth liquid flow. They have simple structures that make it easy to assemble / disassemble, and mount / dismount without tools.

Features

- 1 Easy Handling and Maintenance
Sanitary joints are easily assembled and disassembled by tighten and loosen clamp band by hand.
- 2 Smooth Fluid Flow
Flat shape in side of swivel joint. Using Sweep Elbow. It prevents fluid accumulation by the packing shape and allows smooth fluid flow.
- 3 Compact & Light weight
- 4 Buffing (#400)

NS

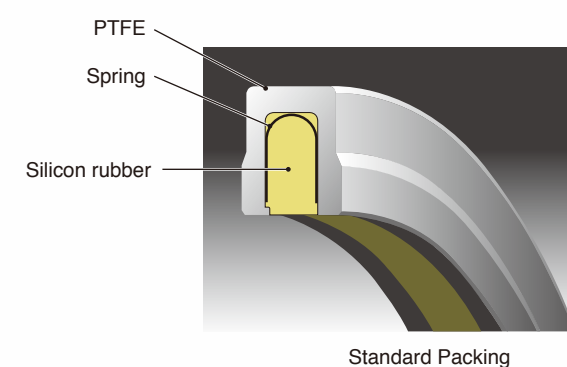
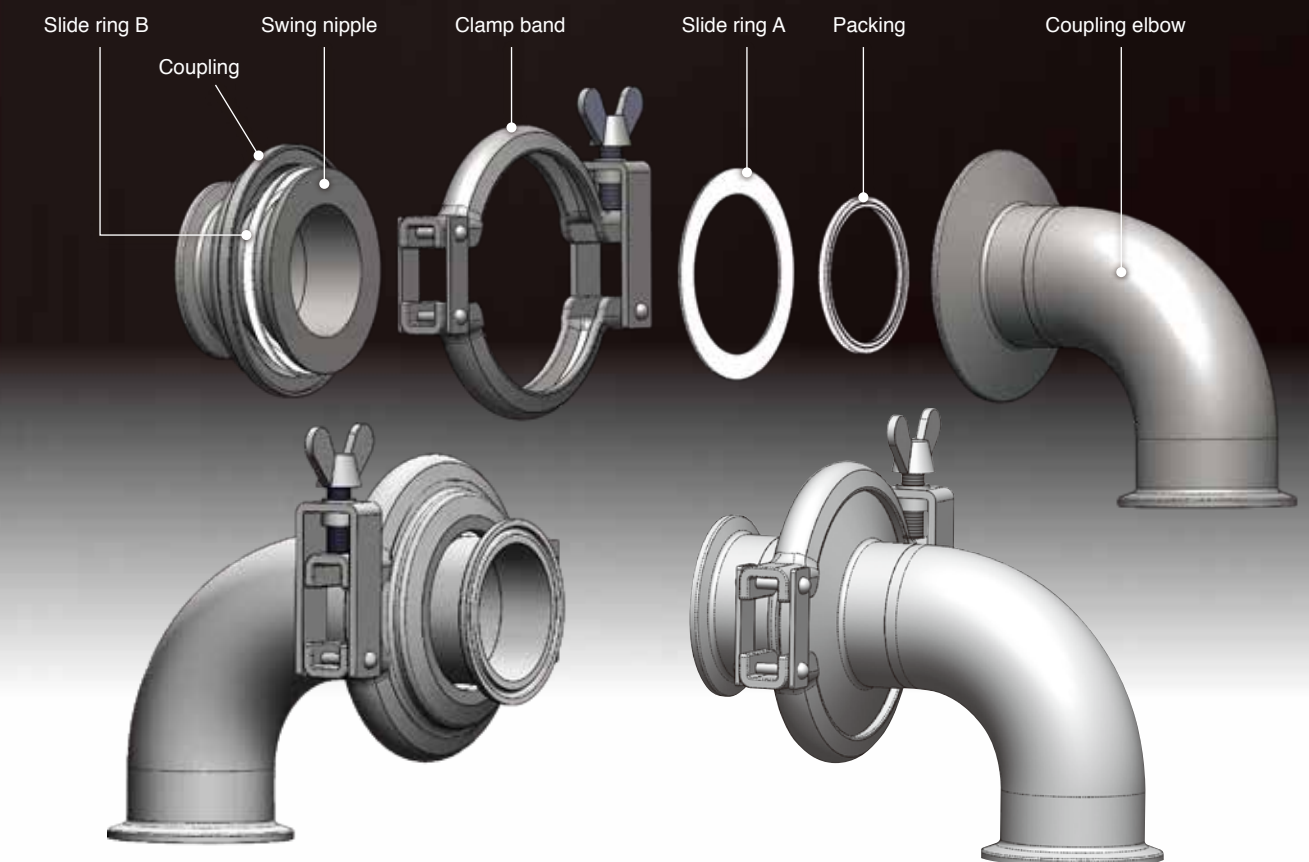

Standard Packing

■Specifications

Nominal Dia. (NPS)	1S · 1-1/2S · 2S · 2-1/2S · 3S · 4S
Style	No.20 · No.30 · No.40
Material	Body: SUS316 Packing: PTFE + Silicon rubber ※Non-silicon type (OFS) is available upon request.
Connection	IDF / ISO Ferrule ※Union and Plain (welded) ends are also available.
Max. Press.	0.98MPa
Temp. range	-10 ~ +150°C

※Non-lubricated type

DIMENSIONS

Standard dimensions of TB-NIIGATA swivel joints are listed below.
If a special dimension is required, consult our sales representatives.

Threaded ends / Bored or beveled for welding

No.20		No.70	
No.30		No.80	
No.40		No.90	
No.50		No.10	
No.60			

※1 For Blue(B), Silver(S) and Orange(SH), please refer "R" and "T" dimension.

Green (G) Threaded ends

(unit : mm)

NPS	Dim.	B	C	D	E	F	G	K	L	P	Q	V
3/8.1/2		75.4	42.9	66.7	118.3	85.8	28.6	38.1	26.7	88.9	109.6	30.5
3/4.1		98.4	63.5	92.1	161.9	127.0	41.3	57.2	41.0	114.3	155.6	46.1
1-1/4.1-1/2		113.5	76.2	108.7	189.7	152.4	58.7	73.0	56.0	126.2	184.9	53.5
2		145.3	87.3	155.6	232.6	174.6	74.6	95.3	74.6	146.8	242.9	65.0
2-1/2.3		174.6	117.5	192.1	292.1	235.0	101.6	125.4	101.6	166.7	202.5	78.4
4		193.7	127.0	231.8	320.7	254.0	127.0	159.0	127.8	182.6	358.8	91.2

Blue (B) Threaded ends / Bored or beveled for welding

(unit : mm)

NPS	Dim.	B	C	D	E	F	G	J	K	L	N	P	Q	R	S	T	V	W	X	Y
3/8.1/2		75.4	42.9	66.7	118.3	85.8	28.6	154.8	38.1	26.7	79.4	88.9	109.6	66.7	146.1	109.6	30.5	70.7	137.4	152.5
3/4.1		98.4	63.5	92.1	161.9	127.0	41.3	204.8	57.2	41.0	106.4	114.3	155.6	92.1	198.4	155.6	46.1	100.0	192.1	219.1
1-1/4.1-1/2		113.5	76.2	108.7	189.7	152.4	58.7	241.3	73.0	56.0	127.8	126.2	184.9	108.7	236.5	184.9	53.5	123.0	231.7	261.1
2		145.3	87.3	155.6	232.6	174.6	74.6	290.6	95.3	74.6	145.3	146.8	242.9	155.6	300.9	242.9	65.0	155.6	311.2	330.2
2-1/2.3		174.6	117.5	192.1	292.1	235.0	101.6	349.2	125.4	101.6	174.6	166.7	320.0	202.5	366.7	309.6	78.4	192.1	384.2	437.5
4		193.7	127.0	231.8	320.7	254.0	127.0	387.4	159.0	127.8	193.7	182.6	358.8	231.8	425.5	358.8	91.2	231.8	463.6	485.8

※Pipe schedule 40

Stainless (SST) Threaded ends / Bored or beveled for welding

(unit : mm)

NPS	Dim.	B	C	D	E	F	G	J	K	L	N	P	Q	S	V	W	X	Y
3/8.1/2		75.4	42.9	66.7	118.3	85.8	28.6	154.8	38.1	26.7	79.4	88.9	109.6	146.1	30.5	70.7	137.4	152.5
3/4.1		98.4	63.5	92.1	161.9	127.0	41.3	204.8	57.2	41.0	106.4	114.3	155.6	198.4	46.1	100.0	192.1	219.1
1-1/4.1-1/2		113.5	76.2	108.7	189.7	152.4	58.7	241.3	73.0	56.0	127.8	126.2	184.9	236.5	53.5	123.0	231.7	261.1
2		145.3	87.3	155.6	232.6	174.6	74.6	290.6	95.3	74.6	145.3	146.8	242.9	300.9	65.0	155.6	311.2	330.2

※Pipe schedule 40

Silver (S) Threaded ends / Bored or beveled for welding

(unit : mm)

NPS	Dim.	B	C	D	E	F	G	J	K	L	N	P	Q	R	S	T	V	W	X	Y
3/8.1/2		71.4	49.2	73.0	120.6	98.4	31.8	150.0	46.8	32.0	78.6	84.1	122.2	73.0	151.6	122.2	33.2	80.2	153.2	171.4
3/4.1		108.7	63.5	107.2	172.2	127.0	44.5	217.4	61.9	44.5	108.7	118.3	170.7	107.2	215.9	170.7	47.7	107.2	214.4	234.2
1-1/4.1-1/2		113.5	76.2	108.7	189.7	152.4	58.7	241.3	73.0	55.9	127.8	126.2	184.9	108.7	236.5	184.9	53.5	123.0	231.7	261.1
2		144.5	98.4	149.2	242.9	196.8	79.4	304.8	104.8	80.8	160.3	160.3	250.8	152.4	309.6	247.6	67.6	165.1	314.3	349.2
2-1/2		146.1	108.0	161.9	254.1	216.0	92.0	309.6	126.0	92.0	163.5	158.9	284.5	176.5	325.5	269.9	80.0	179.4	341.3	392.5

※Pipe schedule 160

Orange (SH) Threaded ends / Beveled for welding Sch160

(unit : mm)

NPS	Dim.	B	C	D	E	F	G	J	K	L	N	P	Q	R	S	T	V	W	X	Y
3/8.1/2		108.7	63.5	107.2	172.2	127.0	44.5	217.4	61.9	44.5	108.7	118.3	170.7	107.2	215.9	170.7	47.7	107.2	214.4	234.2
3/4.1		113.5	76.2	108.7	189.7	152.4	58.7	241.3	73.0	56.0	127.8	126.2	184.9	108.7	236.5	184.9	53.4	123.0	231.7	261.1
1-1/4.1-1/2		144.5	98.4	149.2	242.9	196.8	79.4	304.8	104.8	80.8	160.3	160.4	250.4	152.0	309.6	247.6	67.6	165.1	314.3	348.8
2		146.1	108.0	161.9	254.1	216.0	92.0	309.6	126.0	94.8	163.5	158.8	284.5	176.5	325.5	269.9	80.0	179.4	341.3	392.5

DIMENSIONS

Flanged ends

No.20

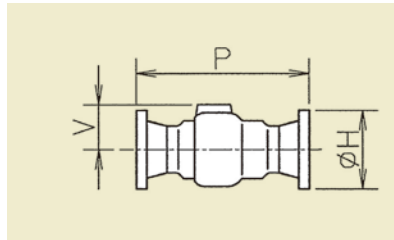

No.70

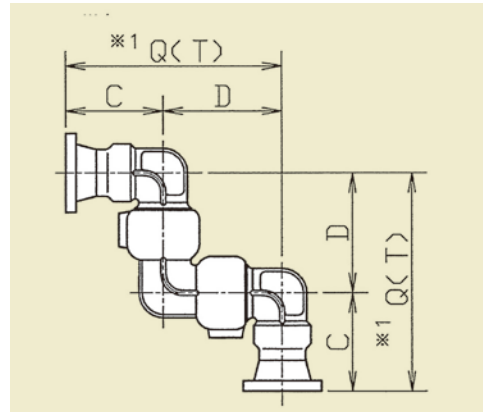

No.30

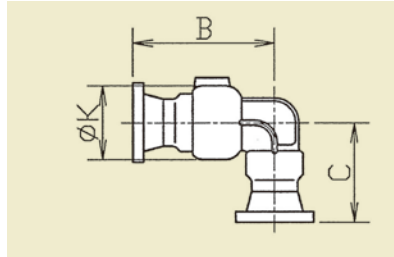

No.80

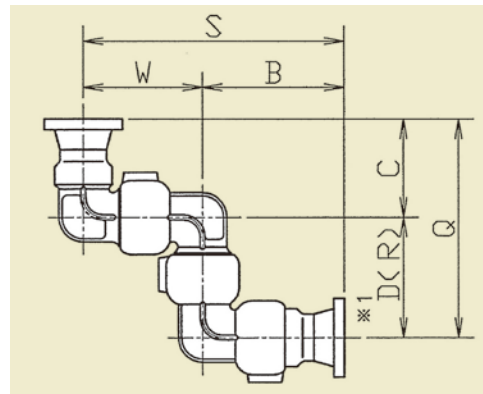

No.40

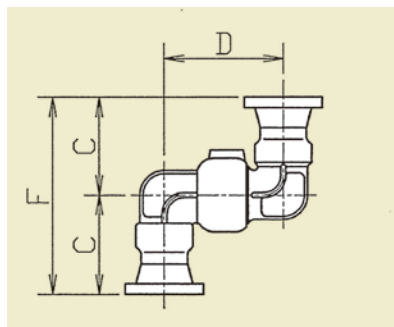

No.90

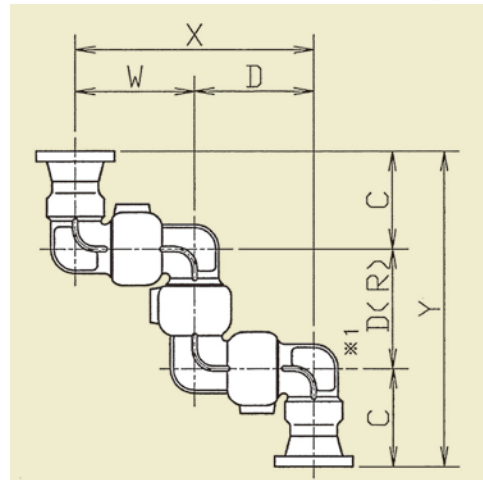

No.50

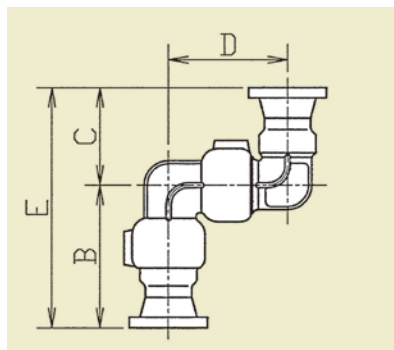

No.10

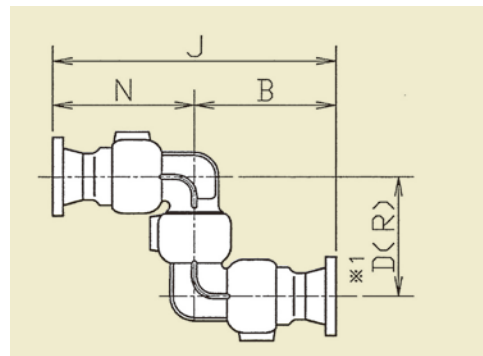

No.60

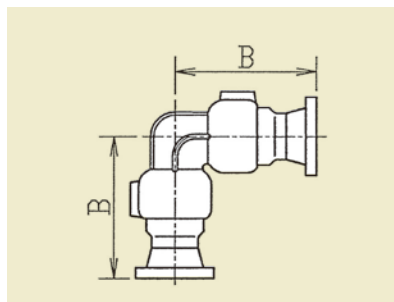

Blue (B) Flanged ends

(unit : mm)

NPS	Dim.	B	C	D	E	F	H	J	K	N	P	Q	R	S	T	V	W	X	Y
3/8		123.0	90.5	66.7	213.5	181.0	-	250.0	38.1	127.0	184.1	157.2	66.7	193.7	157.2	30.5	70.7	137.4	247.7
1/2		123.0	90.5	66.7	213.5	181.0	89.0	250.0	38.1	127.0	184.1	157.2	66.7	193.7	157.2	30.5	70.7	137.4	247.7
3/4		150.8	115.9	92.1	266.7	231.8	99.0	309.6	57.2	158.8	219.1	208.0	92.1	250.8	208.0	46.1	100.0	192.1	323.9
1		154.0	119.1	92.1	273.1	238.2	108.0	316.0	57.2	162.0	225.5	211.2	92.1	254.0	211.2	46.1	100.0	192.1	330.3
1-1/4		170.7	133.4	108.7	304.1	266.8	117.0	355.7	73.0	185.0	240.6	242.1	108.7	293.7	242.1	53.5	123.0	231.7	375.5
1-1/2		175.4	138.1	108.7	313.5	276.2	127.0	365.1	73.0	189.7	250.0	246.8	108.7	298.4	246.8	53.5	123.0	231.7	384.9
2		208.8	150.8	155.6	359.6	301.6	152.0	417.6	95.3	208.8	273.8	306.4	155.6	364.4	306.4	65.0	155.6	311.2	457.2
2-1/2		244.5	187.4	192.1	431.9	374.8	178.0	489.0	125.4	244.5	306.5	389.9	202.5	436.6	379.5	78.4	192.1	384.2	577.3
3		244.5	187.4	192.1	431.9	374.8	190.0	489.0	125.4	244.5	306.5	389.9	202.5	436.6	379.5	78.4	192.1	384.2	577.3
4		269.9	203.2	231.8	473.1	406.4	229.0	539.8	159.0	269.9	335.0	435.0	231.8	501.7	435.0	91.2	231.8	463.6	638.2

※Pipe schedule 40

Stainless (SST) Flanged ends

(unit : mm)

NPS	Dim.	B	C	D	E	F	H	J	K	N	P	Q	S	V	W	X	Y
3/8		123.0	90.5	66.7	213.5	181.0	-	250.0	38.1	127.0	184.1	157.2	193.7	30.5	70.7	137.4	247.7
1/2		123.0	90.5	66.7	213.5	181.0	89.0	250.0	38.1	127.0	184.1	157.2	193.7	30.5	70.7	137.4	247.7
3/4		150.8	115.9	92.1	266.7	231.8	99.0	309.6	57.2	158.8	219.1	208.0	250.8	46.1	100.0	192.1	323.9
1		154.0	119.1	92.1	273.1	238.2	108.0	316.0	57.2	162.0	225.5	211.2	254.0	46.1	100.0	192.1	330.3
1-1/4		170.7	133.4	108.7	304.1	266.8	117.0	355.7	73.0	185.0	240.6	242.1	293.7	53.5	123.0	231.7	375.5
1-1/2		175.4	138.1	108.7	313.5	276.2	127.0	365.1	73.0	189.7	250.0	246.8	298.4	53.5	123.0	231.7	384.9
2		208.8	150.8	155.6	359.6	301.6	152.0	417.6	95.3	208.8	273.8	306.4	364.4	65.0	155.6	311.2	457.2

※Pipe schedule 40

Silver (S) Flanged ends JIS21MPa

(unit : mm)

NPS	Dim.	B	C	D	E	F	H	J	K	N	P	Q	R	S	T	V	W	X	Y
1/2		119.0	96.8	73.0	215.8	193.6	63.0	245.2	46.8	126.2	179.3	169.8	73.0	199.2	169.8	33.2	80.2	153.2	266.6
3/4		161.1	115.9	107.2	277.0	231.8	68.0	322.2	61.9	161.1	223.1	223.1	107.2	268.3	223.1	47.7	107.2	214.4	339.0
1		164.3	119.1	107.2	283.4	238.2	80.0	328.6	61.9	164.3	229.5	226.3	107.2	271.5	226.3	47.7	107.2	214.4	345.4
1-1/4		170.7	133.4	108.7	304.1	266.8	90.0	355.7	73.0	185.0	240.6	242.1	108.7	293.7	242.1	53.5	123.0	231.7	375.5
1-1/2		175.4	138.1	108.7	313.5	276.2	100.0	365.1	73.0	189.7	250.0	246.8	108.7	298.4	246.8	53.5	123.0	231.7	384.9
2		208.0	161.9	149.2	369.9	323.8	112.0	431.8	104.8	223.8	287.3	314.3	152.4	373.1	311.1	67.6	165.1	314.3	476.2
2-1/2		226.1	188.0	161.9	414.1	376.0	140.0	469.6	126.0	243.5	318.9	364.5	176.5	405.5	349.9	80.0	179.4	341.3	552.5

※Pipe schedule 160

Orange (SH) Beveled for welding Sch160

(unit : mm)

NPS	Dim.	B	C	D	E	F	H	J	K	N	P	Q	R	S	T	V	W	X	Y
1/2		157.9	112.7	107.2	270.6	225.4	63.0	315.8	61.9	157.9	216.7	219.9	107.2	265.1	219.9	47.6	107.2	214.4	332.6
3/4		167.5	130.2	108.7	297.7	260.4	68.0	349.3	73.0	181.8	234.2	238.9	108.7	290.5	238.9	53.4	123.0	231.7	369.1
1		170.7	133.4	108.7	304.1	266.8	80.0	355.7	73.0	185.0	240.6	242.1	108.7	293.7	242.1	53.4	123.0	231.7	375.5
1-1/4		203.3	157.2	149.2	360.5	314.4	90.0	422.4	104.8	219.1	278.0	309.2	152.0	368.4	306.4	67.6	165.1	314.3	466.4
1-1/2		208.0	161.9	149.2	369.9	323.8	100.0	431.8	104.8	223.8	287.4	313.9	152.0	373.1	311.1	67.6	165.1	314.3	475.8
2		211.2	173.1	161.9	384.3	346.2	112.0	439.8	126.0	228.6	289.0	349.6	176.5	390.6	335.0	80.0	179.4	341.3	522.7

※Pipe schedule 160

※1 For Blue(B), Silver(S) and Orange(SH), please refer "R" and "T" dimension.

※2 "H" dimensions of Silver and Orange show outside diameters of JIS21MPa SHA · SHB flange. Other dimensions show that of JPI150Lb.

DIMENSIONS

Beveled for Welding

No.20

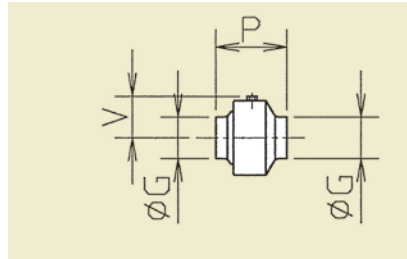

No.70

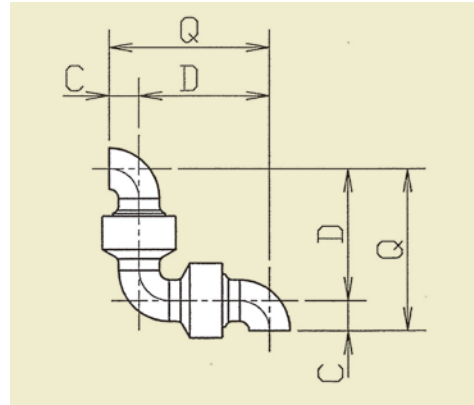

No.30

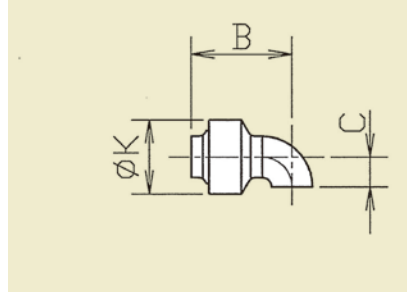

No.80

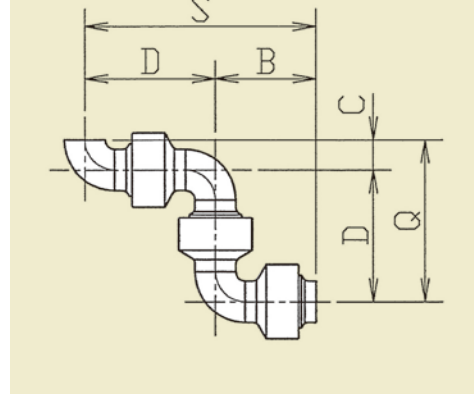

No.40

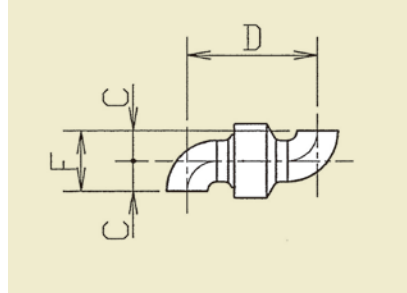

No.90

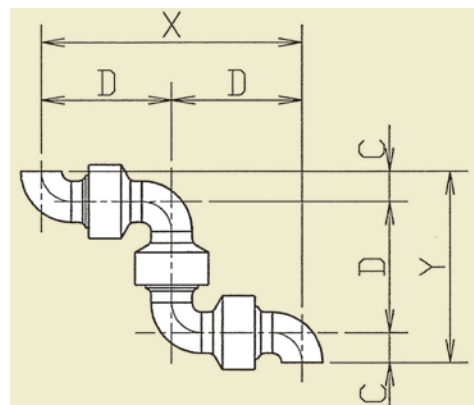

No.50

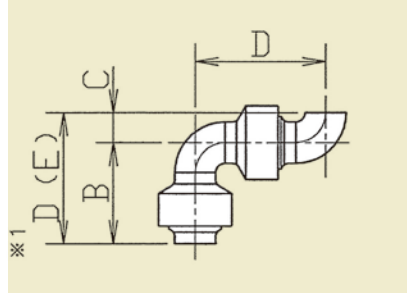

No.10

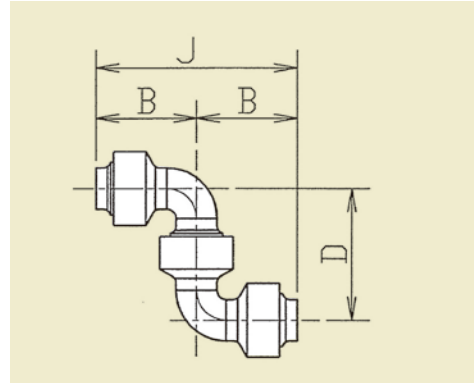

No.60

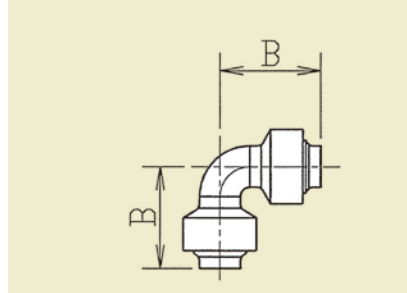

Blue (B) Beveled for welding Sch40

(unit : mm)

NPS	Dim.	B	C	D	F	G	J	K	P	Q	S	X	Y
5		295.9	127.0	422.9	254.0	139.8	591.8	220.0	168.9	549.9	718.8	845.8	676.9
6		315.9	152.4	468.3	304.8	165.2	631.8	239.7	163.5	620.7	784.2	936.6	773.1
8		387.4	203.2	590.6	406.4	216.3	774.8	286.8	184.2	793.8	978.0	1181.2	997.0
10		501.7	254.0	755.7	508.0	267.4	1003.4	338.2	247.7	1009.7	1257.4	1511.4	1263.7
12		577.9	304.8	882.7	609.6	318.5	1155.8	403.2	273.1	1187.5	1460.6	1765.4	1492.3

Stainless (SST) Beveled for welding Sch40

(unit : mm)

NPS	Dim.	B	C	D	F	G	J	K	P	Q	S	V	X	Y
2-1/2		213.3	63.5	276.8	127.0	76.3	426.6	130.0	149.8	340.3	490.1	70.1	553.6	403.8
3		226.0	76.2	302.2	152.4	89.1	452.0	130.0	149.8	378.4	528.2	70.1	604.4	454.6
4		254.2	101.6	355.8	203.2	114.3	508.4	155.0	152.6	457.4	610.0	83.3	711.6	559.0
5		295.9	127.0	422.9	254.0	139.8	591.8	220.0	168.9	549.9	718.8	—	845.8	676.9
6		315.9	152.4	468.3	304.8	165.2	631.8	240.0	163.5	620.7	784.2	—	936.6	773.1
8		387.4	203.2	590.6	406.4	216.3	774.8	290.0	184.2	793.8	978.0	—	1181.2	997.0
10		501.7	254.0	755.7	508.0	267.4	1003.4	338.2	247.7	1009.7	1257.4	—	1511.4	1263.7
12		577.9	304.8	882.7	609.6	318.5	1155.8	403.2	273.1	1187.5	1460.6	—	1765.4	1492.3

Type N (N) Beveled for welding Sch40

(unit : mm)

NPS	Dim.	B	C	D	F	G	J	K	P	Q	S	V	X	Y
2-1/2		213.3	63.5	276.8	127.0	76.3	426.6	128.0	149.8	340.3	490.1	70.1	553.6	403.8
3		226.0	76.2	302.2	152.4	89.1	452.0	128.0	149.8	378.4	528.2	70.1	604.4	454.6
4		254.2	101.6	355.8	203.2	114.3	508.4	155.0	152.6	457.4	610.0	83.3	711.6	559.0
6		295.7	152.4	448.1	304.8	165.2	591.4	216.0	143.3	600.5	743.8	109.8	896.2	752.9
8		346.5	203.2	549.7	406.4	216.3	693.0	265.0	143.3	752.9	896.2	133.7	1099.4	956.1
10		436.9	254.0	690.9	508.0	267.4	873.8	320.0	182.9	944.9	1127.8	165.2	1381.8	1198.9
12		487.7	304.8	792.5	609.6	318.5	975.4	372.0	182.9	1097.3	1280.2	190.4	1585.0	1402.1

Type SN (SN) Beveled for welding Sch160

(unit : mm)

NPS	Dim.	B	C	D	F	G	J	K	P	Q	S	V	X	Y
3		230.7	76.2	306.9	152.4	89.1	461.4	160.0	154.5	383.1	537.6	89.7	613.8	459.3
4		267.6	101.6	369.2	203.2	114.3	535.2	195.0	166.0	470.8	636.8	106.8	738.4	572.4

Orange (SH) Beveled for welding Sch160

(unit : mm)

NPS	Dim.	B	C	D	E	F	G	J	K	P	Q	S	V	X	Y
2-1/2		256.0	63.5	321.1	319.5	127.0	76.3	512.0	160.0	190.9	384.6	577.1	90.7	642.2	448.1
3		268.7	76.2	346.5	344.9	152.4	89.1	537.4	160.0	190.9	422.7	615.2	89.7	693.0	498.9
4		320.3	101.6	423.5	421.9	203.2	114.3	640.6	195.0	217.1	525.1	743.8	100.0	847.0	626.7
5		353.9	127.0	482.5	480.9	254.0	139.8	707.8	230.0	225.3	609.5	836.4	124.6	965.0	736.5

※1 For Orange(SH), please refer "E" dimension.

※2 The shapes of Type SN are different from the above.

DIMENSIONS

Flanged Ends

No.20

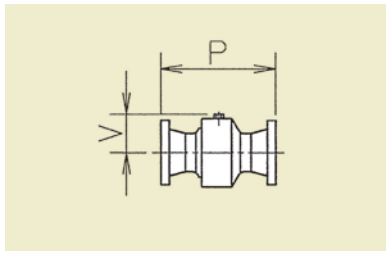

No.70

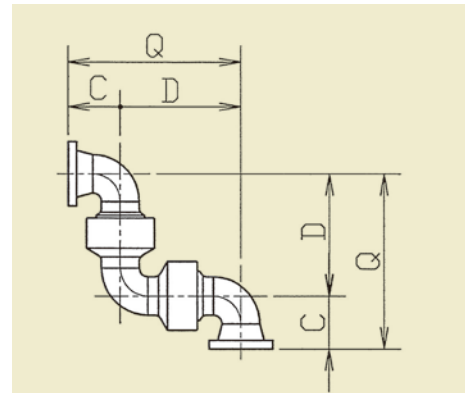

No.30

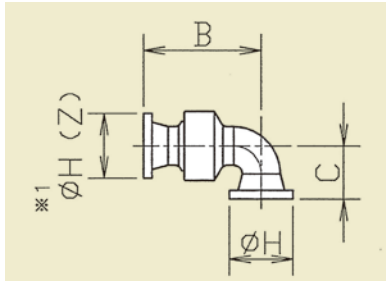

No.80

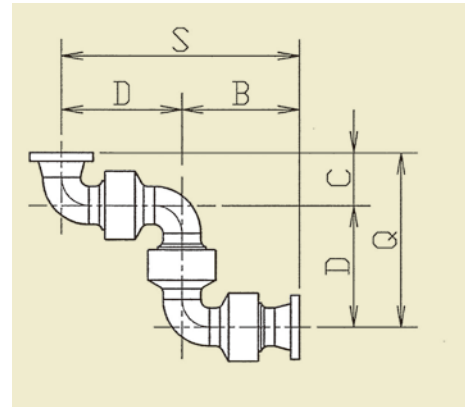

No.40

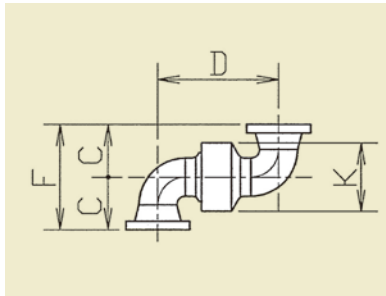

No.90

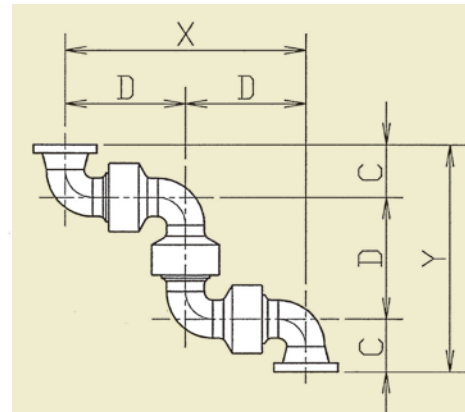

No.50

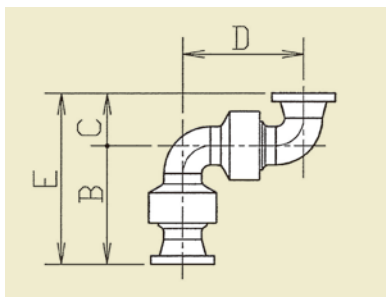

No.10

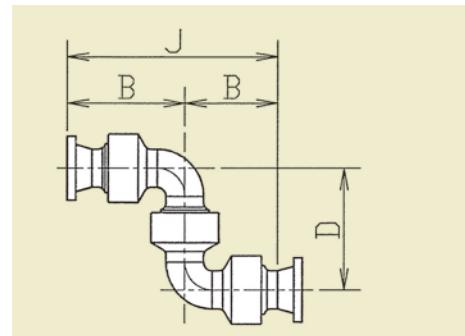

No.60

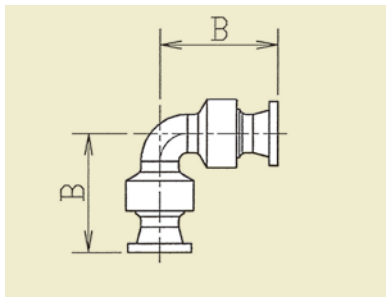

Blue (B) Flanged ends

(unit : mm)

NPS	Dim.	B	C	D	E	F	H	J	K	P	Q	S	X	Y
5		384.8	215.9	422.9	600.7	431.8	254.0	769.6	220.0	346.7	638.8	807.7	845.8	854.7
6		404.8	241.3	468.3	646.1	482.6	279.0	809.6	239.7	341.3	709.6	873.1	936.6	950.9
8		489.0	304.8	590.6	793.8	609.6	343.0	978.0	286.8	387.4	895.4	1079.6	1181.2	1200.2
10		603.3	355.6	755.7	958.9	711.2	406.0	1206.6	338.2	450.9	1111.3	1359.0	1511.4	1466.9
12		692.2	419.1	882.7	1111.3	838.2	483.0	1384.4	403.2	501.7	1301.8	1574.9	1765.4	1720.9

※Pipe schedule 40

Stainless (SST) Flanged ends

(unit : mm)

NPS	Dim.	B	C	D	E	F	H	J	K	P	Q	S	V	X	Y
2-1/2		283.2	133.4	276.8	416.6	266.8	178.0	566.4	130.0	289.6	410.2	560.0	70.1	553.6	543.6
3		295.9	146.1	302.2	442.0	292.2	190.0	591.8	130.0	289.6	448.3	598.1	70.1	604.4	594.4
4		330.4	177.8	355.8	508.2	355.6	229.0	660.8	155.0	305.0	533.6	686.2	83.3	711.6	711.4
5		384.8	215.9	422.9	600.7	431.8	254.0	769.6	220.0	346.7	638.8	807.7	-	845.8	854.7
6		404.8	241.3	468.3	646.1	482.6	279.0	809.6	240.0	341.3	709.6	873.1	-	936.6	950.9
8		489.0	304.8	590.6	793.8	609.6	343.0	978.0	290.0	387.4	895.4	1079.6	-	1181.2	1200.2
10		603.3	355.6	755.7	958.9	711.2	406.0	1206.6	338.2	450.9	1111.3	1359.0	-	1511.4	1466.9
12		692.2	419.1	882.7	1111.3	838.2	483.0	1384.4	403.2	501.7	1301.8	1574.9	-	1765.4	1720.9

※Pipe schedule 40

TypeN (N) Flanged ends

(unit : mm)

NPS	Dim.	B	C	D	E	F	H	J	K	P	Q	S	V	X	Y
2-1/2		283.2	133.4	276.8	416.6	266.8	178.0	566.4	128.0	289.6	410.2	560.0	70.1	553.6	543.6
3		295.9	146.1	302.2	442.0	292.2	190.0	591.8	128.0	289.6	448.3	598.1	70.1	604.4	594.4
4		330.4	177.8	355.8	508.2	355.6	229.0	660.8	155.0	305.0	533.6	686.2	83.3	711.6	711.4
6		384.6	241.3	448.1	625.9	482.6	279.0	769.2	216.0	321.1	689.4	832.7	109.8	896.2	930.7
8		448.1	304.8	549.7	752.9	609.6	343.0	896.2	265.0	346.5	854.5	997.8	133.7	1099.4	1159.3
10		538.5	355.6	690.9	894.1	711.2	406.0	1077.0	320.0	386.1	1046.5	1229.4	165.2	1381.8	1402.1
12		602.0	419.1	792.5	1021.1	838.2	483.0	1204.0	372.0	411.5	1211.6	1394.5	190.4	1585.0	1630.7

※Pipe schedule 40

BD · BDR Flanged ends

(unit : mm)

NPS	Dim.	B	C	D	F	H	K	P	V	Z
2-1/2		283.2	133.4	276.8	266.8	178.0	130.0	289.6	77.1	178.0
3		295.9	146.1	302.2	292.2	190.0	130.0	289.6	77.1	190.0
4		330.4	177.8	355.8	355.6	229.0	155.0	305.0	90.3	229.0
6		404.8	241.3	468.3	482.6	279.0	240.0	341.3	130.8	279.0
8		489.0	304.8	590.6	609.6	343.0	295.0	387.4	157.0	343.0
10		603.3	355.6	755.7	711.2	406.0	344.0	450.9	182.6	406.0
12		692.2	419.1	882.7	838.2	483.0	403.0	501.7	212.0	483.0

※Pipe schedule 40

BD · BDR Different size flanged ends (Style No.30)

(unit : mm)

NPS	Dim.	B	C	H	K	Z
3×2-1/2		283.2	133.4	178.0	130.0	190.0
4×3		295.9	146.1	190.0	130.0	229.0
6×4		330.4	177.8	229.0	155.0	279.0
8×6		404.8	241.3	279.0	240.0	343.0
10×8		489.0	304.8	343.0	295.0	406.0
12×10		603.3	355.6	406.0	344.0	483.0
14×12		692.2	419.1	483.0	403.0	535.0

※Pipe schedule 40

Type SN (SN) Flanged ends JIS21MPa

(unit : mm)

NPS	Dim.	B	C	D	E	F	H	J	P	Q	S	V	X	Y
3		315.7	161.2	306.9	476.9	322.4	155.0	631.4	324.5	468.1	622.6	106.8	613.8	629.3

※NPS 4 flanges are out of JIS standards, but available upon request.

※Pipe schedule 160

Orange (SH) Flanged ends JIS21MPa

(unit : mm)

NPS	Dim.	B	C	D	E	F	H	J	K	P	Q	S	V	X	Y
2-1/2		337.6	145.1	321.1	482.7	290.2	140.0	675.2	160.0	354.1	466.2	658.7	90.7	642.2	611.3
3		355.3	162.8	346.5	518.1	325.6	155.0	710.6	160.0	364.1	509.3	701.8	89.7	693.0	672.1

※NPS 4 & 5 flanges are out of JIS standards, but available upon request.

※Pipe schedule 160

※1 For BD · BDR, please refer "Z" dimension.

※2 The shapes of Type SN are different from the above.

※3 "H (Z)" dimensions of Silver, SN and Orange show outside dimeters of JIS21MPa SHA · SHB flange. Other dimensions as how that of JPI150Lb.

DIMENSIONS

Super High Pressure Balanced Type

No.30

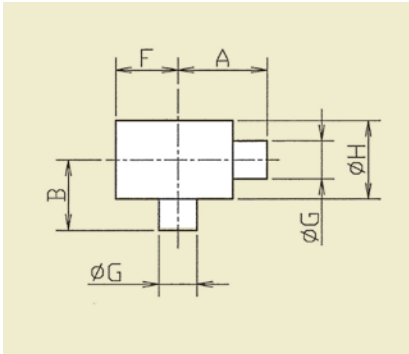

No.70

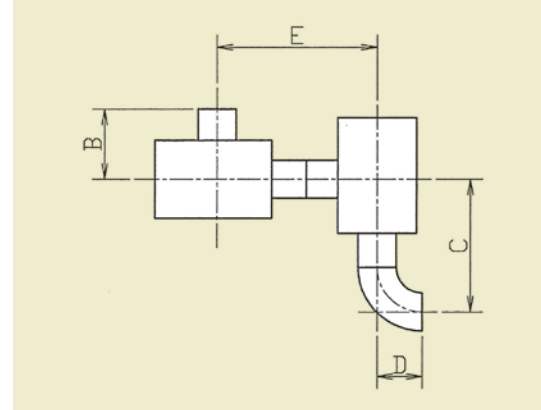

No.40

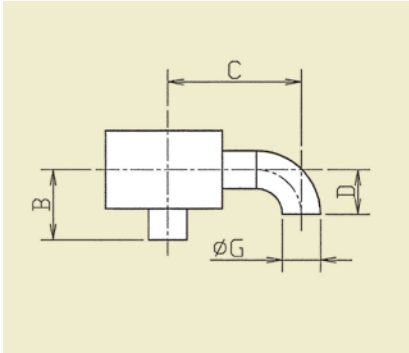

No.80

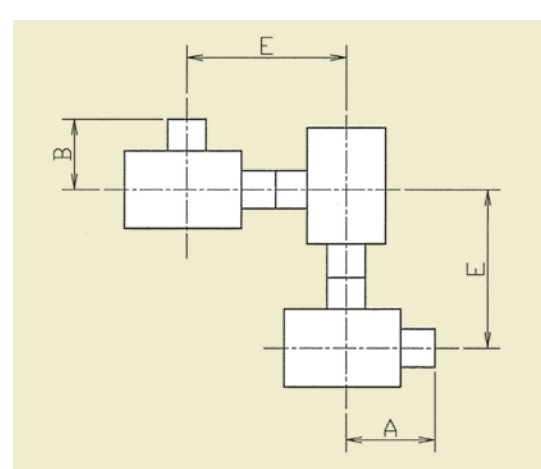

No.50

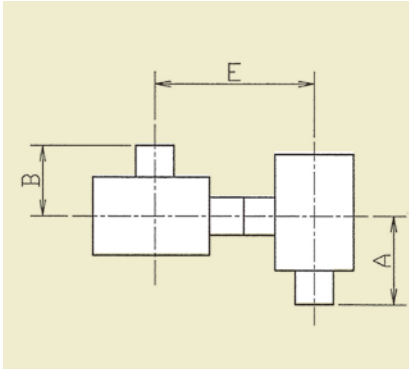

No.90

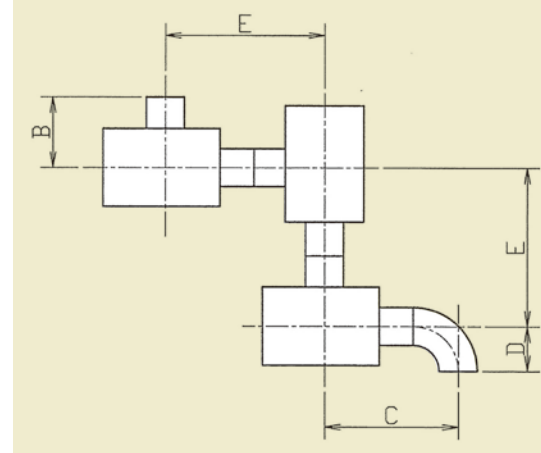

Sanitary Type

No.20

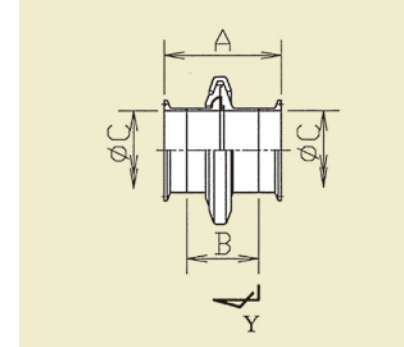

No.40

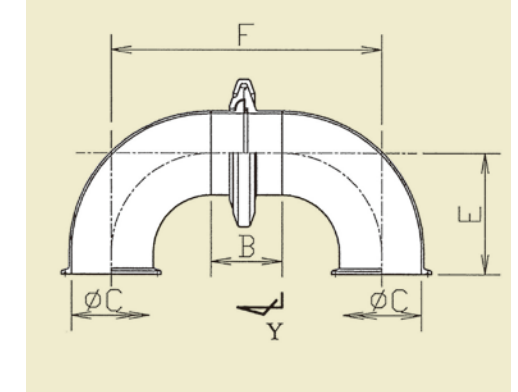

No.30

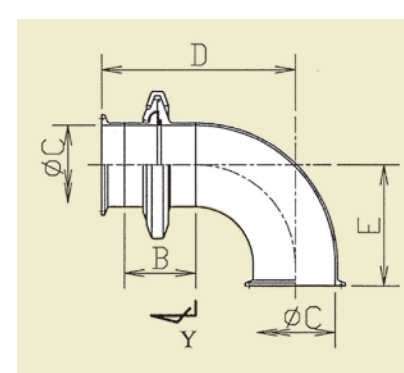

NPS:1~2S

CLAMP BANDS

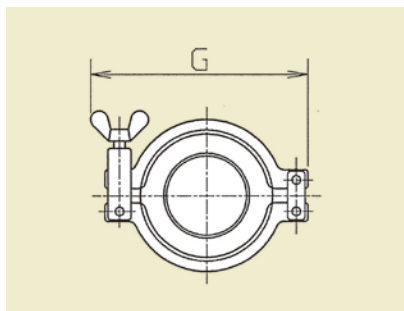

NPS:2-1/2~4S

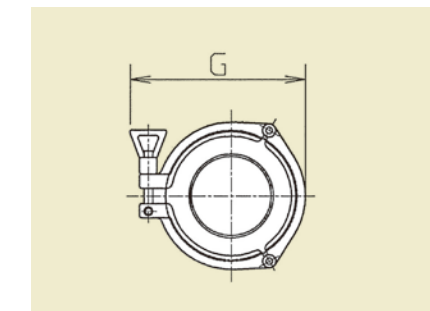

■NSB Beveled for welding Sch160 (unit : mm)

NPS	Dim.	A	B	C	D	E	F	G	H
1		80.0	65.0	118.1	38.1	145.0	55.0	34.0	75.0
1-1/4		113.0	85.0	160.6	47.6	198.0	79.0	42.7	100.0
1-1/2		113.0	90.0	170.2	57.2	203.0	79.0	48.6	100.0
2		145.0	120.0	195.8	50.8	265.0	107.5	60.5	130.0
2-1/2		177.0	135.0	240.5	63.5	312.0	122.0	76.3	160.0
3		180.0	145.0	256.2	76.2	325.0	124.5	89.1	180.0
4		200.0	180.0	301.6	101.6	380.0	148.0	114.3	220.0

■NPB Beveled for welding Sch160 (unit : mm)

NPS	Dim.	A	B	C	D	E	F	G	H
3		112.0	105.0	188.2	76.2	217.0	103.0	89.1	166.0
4		130.0	130.0	231.6	101.6	260.0	120.0	114.3	218.0
5		177.0	153.0	304.0	127.0	330.0	162.0	139.8	247.0

■Sanitary (unit : mm)

NPS	Dim.	A	B	C	D	E	F	G
1S		87.0	46.0	23.0	101.5	55.0	116.0	112.5
1-1/2S		92.5	51.5	35.7	122.0	70.0	151.5	134.5
2S		92.5	51.5	47.8	134.0	82.0	175.5	148.5
2-1/2S		105.5	64.5	59.5	170.0	105.0	234.5	146.0
3S		105.5	64.5	72.3	175.0	110.0	244.5	159.5
4S		111.5	70.5	97.6	224.4	160.0	337.3	198.0

WEIGHTS LIST

Green (G) Threaded ends (unit : kg)

NPS	Style#	20	30	40	50	60	70
3/8		0.4	0.5	0.6	0.8	0.7	0.9
1/2		0.4	0.5	0.5	0.8	0.7	0.8
3/4		1.1	1.3	1.5	2.1	1.9	2.3
1		0.9	1.2	1.4	1.9	1.7	2.1
1-1/4		1.8	2.4	2.9	3.6	3.2	4.1
1-1/2		1.5	2.2	2.6	3.4	3.0	3.8
2		3.1	4.1	5.1	7.2	6.2	8.1
2-1/2		6.1	8.0	10.0	13.0	11.1	15.0
3		4.8	6.8	8.9	11.7	9.6	13.8
4		6.9	9.6	12.6	17.0	14.1	20.0

Blue (B) Threaded ends / Bored or beveled for welding (unit : kg)

NPS	Style#	20	30	40	50	60	70	80	90	10
3/8		0.5	0.5	0.6	0.9	0.8	1.0	1.2	1.3	1.1
1/2		0.4	0.4	0.6	0.9	0.7	1.0	1.2	1.3	1.0
3/4		1.2	1.5	1.8	2.3	2.0	2.7	3.3	3.6	2.9
1		1.0	1.2	1.5	2.1	1.8	2.4	3.0	3.4	2.7
1-1/4		1.9	2.4	3.1	4.2	3.5	4.9	6.0	6.7	5.3
1-1/2		1.7	2.1	2.8	3.9	3.2	4.5	5.7	6.3	5.0
2		3.4	4.8	6.0	8.0	6.8	9.3	11.5	12.8	10.3
2-1/2		7.0	12.2	18.2	20.7	14.7	26.6	28.9	34.9	23.0
3		5.6	9.4	13.9	17.7	13.2	22.1	25.9	30.4	21.5
4		7.6	10.7	14.4	19.5	15.8	23.3	28.7	32.4	24.9

Blue (B) Flanged ends JPI150Lb (unit : kg)

NPS	Style#	20	30	40	50	60	70	80	90	10
1/2		1.4	1.4	1.6	1.9	1.7	2.0	2.2	2.3	2.0
3/4		2.6	2.9	3.2	3.7	3.4	4.1	4.7	5.0	4.3
1		3.2	3.5	3.8	4.3	4.0	4.7	5.3	5.6	5.0
1-1/4		4.8	5.3	6.0	7.1	6.4	7.8	8.9	9.6	8.2
1-1/2		5.4	6.0	6.6	7.7	7.0	8.3	9.5	10.1	8.8
2		8.4	9.9	11.2	13.2	11.9	14.5	16.7	18.0	15.4
2-1/2		15.0	20.2	25.8	28.7	23.1	34.4	37.0	42.7	31.4
3		15.9	19.9	24.2	27.9	23.5	32.2	36.2	40.5	31.8
4		21.8	25.0	28.7	33.8	30.1	37.4	42.9	46.6	39.2
5		38.1	42.4	46.7	67.1	62.8	71.4	91.8	96.1	87.5
6		43.1	49.7	56.3	77.6	71.0	84.2	105.5	112.1	98.9
8		66.4	79.8	93.2	123.8	110.4	137.2	167.8	181.2	154.4
10		100.9	124.5	148.1	199.0	175.4	222.6	273.5	297.1	249.9
12		154.7	192.2	229.7	307.0	269.5	344.5	421.8	459.3	384.3

Blue (B) Beveled for welding Sch40 (unit : kg)

NPS	Style#	20	30	40	50	60	70	80	90	10
5		20.4	24.7	29.0	49.4	45.1	53.7	74.1	78.4	69.8
6		21.3	27.9	34.5	55.8	49.2	62.4	83.7	90.3	77.1
8		30.6	44.0	57.4	88.0	74.6	101.4	132.0	145.4	118.6
10		50.9	74.5	98.1	149.0	125.4	172.6	223.5	247.1	199.9
12		77.3	114.8	152.3	229.6	192.1	267.1	344.4	381.9	306.9

Stainless (SST) Threaded ends / Bored or beveled for welding (unit : kg)

NPS	Style#	20	30	40	50	60	70	80	90	10
3/8		0.4	0.5	0.6	0.8	0.7	1.0	1.2	1.3	1.0
1/2		0.4	0.5	0.6	0.8	0.7	0.9	1.1	1.2	1.0
3/4		1.2	1.5	1.8	2.5	2.2	2.9	3.5	3.9	3.1
1		1.0	1.3	1.6	2.4	2.0	2.7	3.3	3.7	3.0
1-1/4		2.0	2.6	3.3	4.3	3.6	5.1	6.1	6.8	5.3
1-1/2		1.7	2.4	3.0	4.0	3.4	4.7	5.8	6.4	5.1
2		3.5	4.7	6.1	8.4	7.0	9.8	11.9	13.3	10.5

Stainless (SST) Beveled for welding Sch40 (unit : kg)

NPS	Style#	20	30	40	50	60	70	80	90	10
2-1/2		6.4	7.3	8.2	14.6	13.7	15.6	22.0	22.9	21.0
3		5.5	6.9	8.2	13.7	12.4	15.1	20.6	22.0	19.2
4		7.1	9.7	12.3	19.4	16.8	22.0	29.1	31.7	26.5
5		20.7	25.1	29.4	50.1	45.8	54.5	75.2	79.5	70.8
6		22.7	29.4	36.1	58.8	52.1	65.5	88.2	94.9	81.5
8		31.2	44.8	58.3	89.5	76.0	103.1	134.3	147.8	120.7
10		51.7	75.5	99.3	151.0	127.2	174.8	226.5	250.3	202.7
12		78.6	116.5	154.4	233.0	195.1	270.9	349.5	387.4	311.6

※The above is the case for Threaded ends

Stainless (SST) Flanged ends JPI150 (unit : kg)

NPS	Style#	20	30	40	50	60	70	80	90	10
1/2		1.4	1.5	1.6	1.8	1.7	1.9	2.1	2.2	2.0
3/4		2.6	2.9	3.2	3.9	3.6	4.3	4.9	5.3	4.5
1		3.3	3.5	3.8	4.6	4.2	4.9	5.6	5.9	5.2
1-1/4		4.9	5.3	6.0	7.2	6.5	7.9	8.9	9.6	8.2
1-1/2		5.5	6.1	6.8	7.9	7.1	8.6	9.6	10.3	8.8
2		8.6	10.0	11.4	13.5	12.2	14.8	17.0	18.3	15.7
2-1/2		14.6	15.6	16.5	22.9	22.0	23.8	30.2	31.1	29.3
3		15.5	16.8	18.2	23.7	22.3	25.1	30.6	31.9	29.2
4		21.2	23.8	26.3	33.4	30.9	36.0	43.1	45.7	40.5
5		38.5	42.9	47.3	68.0	63.6	72.3	93.0	97.4	88.7
6		44.7	51.4	58.1	80.8	74.1	87.5	110.2	116.9	103.5
8		67.4	80.9	94.5	125.7	112.1	139.2	170.4	184.0	156.9
10		102.2	126.0	149.8	201.5	177.7	225.3	277.0	300.8	253.2
12		156.8	194.7	232.6	311.2	273.3	349.1	427.7	465.6	389.8

Type N (N) Flanged ends JPI150Lb (unit : kg)

NPS	Style#	20	30	40	50	60	70	80	90	10
2-1/2		14.5	15.4	16.3	22.6	21.7	23.5	29.8	30.7	28.9
3		15.2	16.5	17.9	23.2	21.8	24.5	29.8	31.2	28.5
4		20.7	23.3	25.8	32.6	30.1	35.2	42.0	44.6	39.4
6		37.0	43.6	50.3	65.5	58.8	72.1	87.3	93.9	80.7
8		55.9	69.3	82.7	102.8	89.4	116.2	136.3	149.7	122.9
10		83.8	107.4	131.0	164.8	141.2	188.4	222.2	245.8	198.6
12		121.6	159.1	196.6	240.8	203.3	278.3	322.5	360.0	185.0

Type N (N) Beveled for welding Sch40 (unit : kg)

NPS	Style#	20	30	40	50	60	70	80	90	10
2-1/2		6.3	7.2	8.1	14.4	13.5	15.3	21.6	22.5	20.7
3		5.3	6.7	8.0	13.3	12.0	14.7	20.0	21.3	18.6
4		6.8	9.4	11.9	18.7	16.2	21.3	28.1	30.6	25.5
6		15.2	21.8	28.5	43.7	37.0	50.3	65.5	72.1	58.9
8		20.1	33.5	46.9	67.0	53.6	80.4	100.5	113.9	87.1
10		33.8	57.4	81.0	114.8	91.2	138.4	172.2	195.8	148.6
12		44.2	81.7	119.2	163.4	125.9	200.9	245.1	282.6	207.6

BDR Flanged ends JPI150Lb (unit : kg)

NPS	Style#	20	30	40	NPS	Style#	30 異径
2-1/2		15.1	16.0	16.9	3×2-1/2		16.9
3		16.2	17.6	19.0	4×3		18.6
4		22.0	24.6	27.2	6×4		26.9
6		45.6	52.2	58.9	8×6		56.0
8		72.4	85.8	99.2	10×8		88.1
10		106.5	130.1	153.7	12×10		136.7
12		158.1	195.6	233.1	14×12		193.3

BD Flanged ends JPI150Lb (unit : kg)

NPS	Style#	20	30	40	NPS	Style#	30 異径
2-1/2		14.8	15.7	17.5	3×2-1/2		16.8
3		16.6	17.9	20.6	4×3		20.3
4		22.0	24.5	29.6	6×4		28.4
6		44.5	51.0	64.1	8×6		58.3
8		68.0	81.3	107.8	10×8		88.9
10		107.0	130.3	177.0	12×10		141.3
12		155.2	192.2	266.3	14×12		199.7

Silver (S) Threaded ends / Bored or beveled for welding (unit : kg)

NPS	Style#	20	30	40	50	60	70	80	90	10
3/8		0.6	0.8	1.0	1.3	1.1	1.5	1.9	2.1	1.7
1/2		0.6	0.7	0.9	1.3	1.1	1.5	1.8	2.0	1.6
3/4		1.4	1.8	2.2	3.1	2.7	3.4	4.3	4.6	3.9
1		1.3	1.6	2.0	2.9	2.5	3.2	4.1	4.4	3.8
1-1/4		1.9	2.4	3.1	4.2	3.5	4.9	6.0	6.7	5.3
1-1/2		1.7	2.1	2.8	3.9	3.2	4.5	5.7	6.3	5.0
2		4.8	6.4	8.3	11.1	9.2	13.0	16.4	18.3	14.5
2-1/2		6.2	8.6	12.2	16.0	12.4	19.6	24.2	27.8	20.6

※The above is the case for Threaded ends

Silver (S) Flanged ends SHA/SHB (unit : kg)

NPS	Style#	20	30	40	50	60	70	80	90	10
1/2		1.9	2.0	2.2	2.6	2.4	2.8	3.1	3.3	2.9
3/4		3.0	3.4	3.8	4.7	4.3	5.0	5.9	6.2	5.5
1		4.0	4.3	4.7	5.5	5.2	5.9	6.8	7.1	6.4
1-1/4		5.4	5.9	6.5	7.6	6.9	8.2	9.4	10.0	8.7
1-1/2		6.6	7.2	7.8						

WEIGHTS LIST

Orange (SH) Threaded ends / Beveled for welding Sch160 (unit : kg)

NPS	Style#	20	30	40	50	60	70	80	90	10
3/8		1.7	2.3	2.8	3.7	3.2	4.2	5.2	5.7	4.8
1/2		1.7	2.3	2.7	3.7	3.2	4.2	5.2	5.7	4.7
3/4		2.3	3.6	4.5	5.6	4.6	6.6	7.9	8.9	6.9
1		2.6	3.5	4.4	5.5	4.5	6.5	7.8	8.8	6.8
1-1/4		6.6	8.8	11.5	14.6	11.9	17.2	21.4	24.1	18.8
1-1/2		6.5	8.6	11.3	14.4	11.7	17.1	21.3	24.0	18.6
2		8.7	12.6	18.6	23.2	17.2	29.3	34.1	40.2	28.1

※The above is the case for Threaded Ends
 ※NPS 3/4B : Sch80

Orange (SH) Flanged ends SHA/SHB (unit : kg)

NPS	Style#	20	30	40	50	60	70	80	90	10
1/2		3.0	3.5	4.0	4.9	4.5	5.4	6.5	6.9	6.0
3/4		4.1	5.1	6.0	7.1	6.2	8.1	9.4	10.4	8.5
1		5.0	5.9	6.9	8.0	7.0	8.9	10.3	11.2	9.3
1-1/4		9.8	12.1	14.9	17.9	15.1	20.6	24.7	27.5	22.0
1-1/2		10.9	13.1	15.8	18.9	16.2	21.5	25.7	28.4	23.0
2		15.0	18.8	24.9	29.5	23.4	35.6	40.4	46.5	34.3

NSB Beveled for welding Sch160 (unit : kg)

NPS	Style#	20	40	50	70	80	90
1-1/4		7.8	8.2	15.6	16.0	23.4	23.8
1-1/2		8.0	8.7	16.0	16.7	24.0	24.7
2		17.9	18.8	35.8	36.7	53.7	54.6
2-1/2		31.0	32.6	62.0	63.6	93.0	94.6
3		40.0	42.6	80.0	82.6	120.0	122.6
4		66.9	72.3	133.8	139.2	200.7	206.1

NPB Beveled for welding Sch160 (unit : kg)

NPS	Style#	30	40
3		20.4	23.0
4		37.1	42.5
5		70.7	80.3

Orange (SH) Beveled for welding Sch160 (unit : kg)

NPS	Style#	20	30	40	50	60	70	80	90	10
2-1/2		15.8	17.4	18.9	34.7	33.2	36.3	52.1	53.6	50.5
3		16.3	18.9	21.4	37.7	35.2	40.3	56.6	59.1	54.0
4		29.0	34.4	39.7	68.7	63.4	74.1	103.1	108.4	97.7
5		39.7	49.4	59.1	98.8	89.1	108.5	148.2	157.9	138.5

※The above is the case for Short elbow types

Orange (SH) Flanged ends SHA/SHB (unit : kg)

NPS	Style#	20	30	40	50	60	70	80	90	10
2-1/2		27.5	29.0	30.6	46.4	44.8	47.9	63.7	65.3	62.2
3		30.7	33.3	35.8	52.1	49.6	54.7	71.0	73.6	68.4

※The above is the case for Short elbow types

NSB Flanged ends SHA/SHB (unit : kg)

NPS	Style#	20	40	50	70	80	90
1-1/4		11.0	11.4	18.8	19.2	26.6	27.0
1-1/2		12.6	13.3	20.6	21.3	28.6	29.3
2		24.0	24.9	41.9	42.8	59.8	60.7
2-1/2		42.7	44.2	73.7	75.2	104.7	106.2
3		54.4	57.0	94.4	97.0	134.4	137.0

Sanitary (unit : kg)

NPS	Style#	20	30	40
1S		0.7	0.8	0.9
1-1/2S		0.8	1.0	1.1
2S		1.1	1.4	1.6
2-1/2S		1.7	2.2	2.6
3S		2.0	2.5	3.0
4S		3.6	4.6	5.6

REPLACEMENT PARTS LIST

Replacement parts vary depending on the model. Kindly refer to the details provided below for more information."

Green (G)

No	DESCRIPTION	MATERIAL	AMOUNT (Per unit)					
			3/8&1/2	3/4&1	1-1/4&1-1/2	2	2-1/2&3	4
1	Grease Retainer Ring	※NBR	1	1	1	1	1	1
2	O Ring	※NBR	1	1	1	1	1	1
3	Dust Cap	NBR	-	1	1	1	1	1
4	Grease Nipple	Nickel Plating C3604	1	1	1	1	1	1
5	Steel Ball	SUJ2	34	40	54	48	66	84
6	Ball Retainer Plug	SS400	1	1	1	1	1	1
7	Packing	※NBR	1	1	1	1	1	1

Blue (B)

No	DESCRIPTION	MATERIAL	AMOUNT (Per unit)											
			3/8&1/2	3/4&1	1-1/4&1-1/2	2	2-1/2&3	4	5	6	8	10	12	
1	Grease Retainer Ring	※NBR	1	1	1	1	1	1	1	1	1	1	1	1
2	O Ring	※NBR	1	1	1	1	1	1	-	-	-	-	-	-
3	Dust Cap	NBR	-	1	1	1	1	1	-	-	-	-	-	-
4	Grease Nipple	Nickel Plating C3604	1	1	1	1	1	1	2	2	2	2	2	2
5	Steel Ball	SUJ2	34	40	54	48	66	84	68	76	96	116	140	
6	Ball Retainer Plug	SS400	1	1	1	1	1	1	-	-	-	-	-	
		NBR	-	-	-	-	-	-	2	2	2	2	2	
7	Packing	※NBR	1	1	1	1	1	1	1	1	1	1	1	
8	Snap Ring	SUS304	-	-	-	-	-	-	2	2	2	2	2	

Stainless (SST)

No	DESCRIPTION	MATERIAL	AMOUNT (Per unit)											
			3/8&1/2	3/4&1	1-1/4&1-1/2	2	2-1/2&3	4	5	6	8	10	12	
1	Grease Retainer Ring	※NBR	1	1	1	1	1	1	1	1	1	1	1	1
2	O Ring	※NBR	1	1	1	1	2	2	-	-	-	-	-	-
3	Dust Cap	NBR	-	1	1	1	-	-	-	-	-	-	-	-
4	Grease Nipple	Nickel Plating C3604	1	1	1	1	1	1	2	2	2	2	2	2
5	Stainless Ball	SUS440C	34	40	54	48	66	84	68	76	96	116	140	
6	Ball Retainer Plug	SUS316	1	1	1	1	2	2	-	-	-	-	-	
		NBR	-	-	-	-	-	-	2	2	2	2	2	
7	Packing	※NBR	1	1	1	1	1	1	1	1	1	1	1	
8	Ball Plug Washer	SUS316	-	-	-	-	2	2	-	-	-	-	-	
9	Snap Ring	SUS304	-	-	-	-	-	-	2	2	2	2	2	

※Material is dependent on the type of fluid and temperature.

REPLACEMENT PARTS LIST

■Type N (N)

No	DESCRIPTION	MATERIAL	AMOUNT (Per unit)					
			2-½&3	4	6	8	10	12
1	Grease Retainer Ring	※NBR	1	1	1	1	1	1
2	O Ring	※NBR	2	2	2	2	-	-
3	Grease Nipple	Nickel Plating C3604	1	1	-	-	-	-
		C3604	-	-	2	2	2	2
4	Steel Ball	SUJ2	66	84	118	150	186	218
5	Ball Retainer Plug	SS400	2	2	2	2	2	2
6	Packing	※NBR	1	1	1	1	1	1
7	Ball Plug Washer	SS400	2	2	2	2	-	-
8	Seal Washer	SPCC-NBR	-	-	-	-	2	2

■Silver (S)

No	DESCRIPTION	MATERIAL	AMOUNT (Per unit)				
			¾&½	¾&1	1-¼&1-½	2	2-½
1	Grease Retainer Ring	※NBR	1	1	1	1	1
2	O Ring	※NBR	1	1	1	1	1
3	Dust Cap	NBR	-	1	1	1	1
4	Grease Nipple	Nickel Plating C3604	1	1	1	1	1
5	Steel Ball	SUJ2	42	42	54	52	62
6	Ball Retainer Plug	SS400	1	1	1	1	1
7	Packing	※NBR	1	1	1	1	1
8	Cotter Pin	SUS304	-	1	1	1	1

■Type SN (SN)

No	DESCRIPTION	MATERIAL	AMOUNT (Per unit)	
			3	4
1	Grease Retainer Ring	※NBR	1	1
2	Steel Ball	SUJ2	56	56
3	Ball Retainer Plug	SS400	2	2
4	Packing	※NBR	1	1
5	O Ring	※NBR	2	2
6	Grease Nipple	Nickel Plating C3604	1	1
7	Wire	SUS304-W1	1	1

■Orange (SH)

No	DESCRIPTION	MATERIAL	AMOUNT (Per unit)					
			¾&½	¾&1	1-¼&1-½	2	2-½&3	4
1	Grease Retainer Ring	※NBR	1	1	1	1	1	1
2	O Ring	※NBR	1	1	1	1	3	3
3	Dust Cap	NBR	1	1	1	1	-	-
4	Grease Nipple	Nickel Plating C3604	1	1	1	1	-	-
		C3604	-	-	-	-	2	2
5	Steel Ball	SUJ2	42	54	52	62	84	102
6	Ball Retainer Plug	SS400	1	1	1	1	3	3
7	Packing	※NBR	1	1	1	1	1	1
8	Cotter Pin	SUS304	1	1	1	1	-	-
9	Wire	SUS304-W1	-	-	-	-	1	1

■BD(Double seal type)

No	DESCRIPTION	MATERIAL	AMOUNT (per unit)					
			2-½&3	4	6	8	10	12
1	X Ring (External)	FPM	1	1	1	1	1	1
2	X Ring (Internal)	※NBR	1	1	1	1	1	1
3	Steel Ball	SUJ2	66	84	76	96	116	140
4	Packing (HHS)	FPM	1	1	1	1	1	1
5	Ball Retainer Plug	MFZnIII-C SS400	2	2	2	2	2	2
6	O Ring	FPM	2	2	2	2	2	2
7	Ball Plug Washer	MFZnIII-C SS400	2	2	-	-	-	-
8	Grease Fitting Plug	SUS316	2	2	2	2	2	2
9	Sheet Packing	PTFE	2	2	2	2	2	2
10	Wire	SUS304-W1	1	1	1	1	1	1

■BDR

No	DESCRIPTION	MATERIAL	AMOUNT (per unit)					
			2-½&3	4	6	8	10	12
1	Packing (Internal Pressure Firstly Seal)	FPM	1	1	1	1	1	1
2	X Ring (Internal Pressure Secondary Seal)	※NBR	1	1	1	1	1	1
3	X Ring (External Pressure Firstly Seal)	FPM	1	1	1	1	1	1
4	X Ring (External Pressure Secondary Seal)	※NBR	1	1	1	1	1	1
5	Steel Ball	SUJ2	66	84	76	96	116	140
6	Ball Retainer Plug	MFZnIII-C SS400	2	2	2	2	2	2
7	O Ring	FPM	2	2	2	2	2	2
8	Ball Plug Washer	MFZnIII-C SS400	2	2	-	-	-	-
9	Square Plug	SUS304	2	2	2	2	2	2
10	Wire	SUS304-W1	1	1	1	1	1	1

■NSB

No	DESCRIPTION	MATERIAL	AMOUNT (per unit)
1	Locking	SS400	1
2	Relief Fitting	Nickel Plating C3604	5
3	Grease Nipple	C3604	2
4	Hexagon Head Bolt	SS400	8
5	Cover	S25C/SS400	1
6	Back Up Ring	SPC-PTFE	2
7	O Ring (Dust Seal)	※NBR	1
8	O Ring (Secondary Seal)	※NBR	2
9	Buffer Ring	※SPC-PTFE NBR	2
10	Washer	SS400	1
11	Nut	SS400	1
12	Bearing	SUJ	1
13	Bearing	SUJ	1

■NPB

No	DESCRIPTION	MATERIAL	AMOUNT (per unit)
1	Relief Fitting	Nickel Plating C3604	2
2	Grease Nipple	C3604	2
3	Locking	SS400	1
4	Hexagon Head Bolt	SS400	4
5	Back Up Ring	SPC-PTFE	2
6	O Ring (Dust Seal)	※NBR	1
7	O Ring (Dust Seal)	※NBR	1
8	O Ring (Main Seal)	※NBR	2
9	Retainer	S45C	1
10	Bearing	SUJ	1
11	Bearing	SUJ	1

※Material is dependent on the type of fluid and temperature.

PACKING UNITS

NO	MAIN APPLICABLE FLUID	℃	CODE
1	Crude oil	-10~+60	55
		+61~+120	HH
2	Gasoline	-10~+60	55
3	Jet fuel (JET-A1, JP4, JP5)	-10~+60	55
4	Naphtha	-10~+60	55
5	Bunker A	-10~+60	55
6	Bunker B, C	-10~+80	00
7	Diesel (Gas oil)	-10~+60	55
8	Kerosene	-10~+60	55
9	Lubricating oil	-10~+80	00
10	Hydraulic oil (Ester phosphate)	-7~+125	HH
11	Hydraulic oil (Water)	-10~+80	00
12	Hydraulic oil (Petro)	-10~+80	00
13	Distilled water	0~+80	00
14	Industrial water	0~+80	00
15	Sea water	0~+100	HH
16	Drilling mud	~+80	00
17	Steam	+100~+200	AD
18	Air (Compressed air)	-10~+80	00
19	Oxygen (Gas, Max.2.94MPa)	-10~+80	00
20	Nitrogen (Gas)	-10~+80	00
21	Natural gas	-10~+71	00
22	Carbon dioxide (CO ₂)	-10~+60	55
23	Liquefied petroleum gas (LPG)	-10~+60	55
24	Ethyl alcohol (Ethanol)	-29~+76	AD
25	Methyl alcohol (Methanol)	-29~+62	AD.6X
26	Sulfuric acid (80 ~ 120%)	0~+37	HH
27	Sodium hydroxide (Caustic soda, 0 ~ 73%)	0~+60	55
28	Ammonia (Anhydrous)	-29~+60	6X

INTERNAL PRESSURE & SWIVEL TORQUE

The following torque curves can be used for estimating various size of Niigata swivel joints at different pressure ratings for normal applications. When torque is critical, consult our sales representatives.

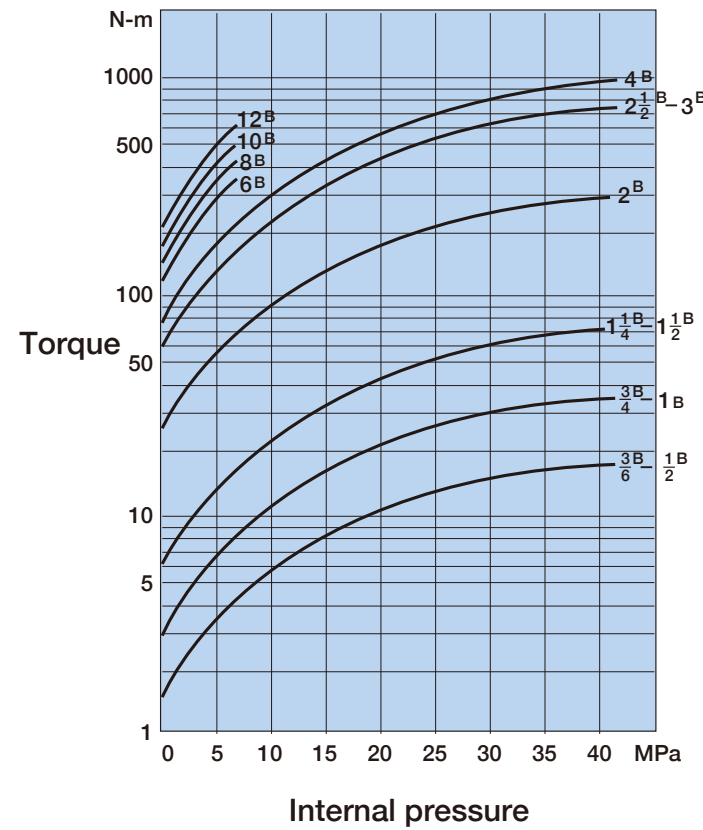

LUBRICANTS (GREASE)

SERVICE	GREACE	RAMARK
For low pressure	Multi-purpose type	+15℃~ +80℃
For high pressure	Extreme pressure multi-purpose type	+15℃~ +80℃
For high temperature	Resist high temperature type	+80℃~ +175℃
	Resist high temperature type (Zolvest240)	+176℃~
For low temperature	Silicon	~-14℃
For EPT	Silicon	for 6X Packing

※Other types of grease are available for chemical, oxygen, or food service etc.

Earthquake isolation system [Willow]

Swivel joint Assembly "Willow"

It follows sudden earthquake tremors and protects important lifelines.



Location of use

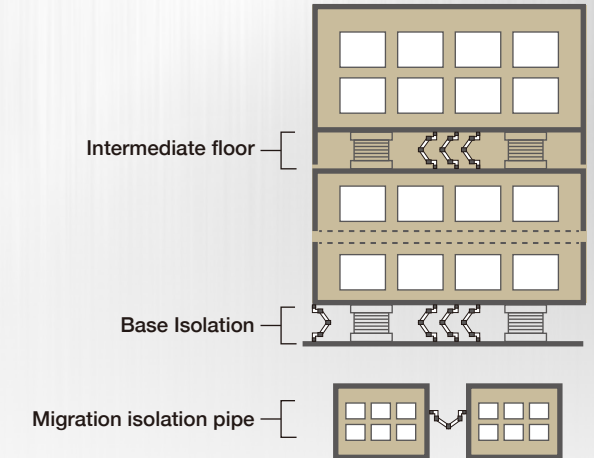

What is Earthquake isolation system ?

The seismic isolation method combines laminated rubber and PTFE plates to absorb shaking during earthquakes. It effectively handles large relative displacements and prevents damage to equipment and piping. Willow can be installed in both base isolation and intermediate floor isolation structures.

Shape of Willow

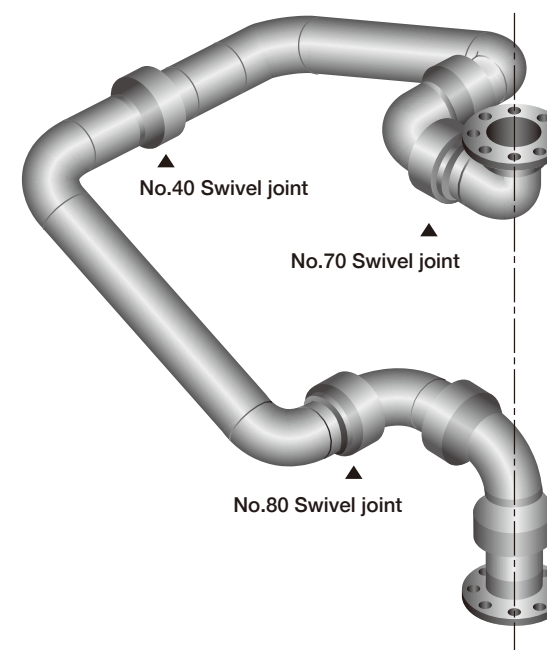

Earthquake isolation system [Willow]

Swivel joint	B SST S SN SH etc.,
Surface finishing	Sivel joint, Flange : KANIZEN Plating
	Pipe, Elbow : Hot dip galvanizing
Application	Chilled water, cold water, cooling water, feed water, pure water, high temperature water, chemicals, food, fire extinguishing, oil, steam

Style No.30-70-50 Combination

This swivel combination is generally used for absorption of swing motion and mechanical vibration in vertical dog-leg piping. In case alignment of piping system and the operating condition are severe, style No.50-40-80 assembly assure trouble-free performance.

Applications
Descaling header of rolling mill, injection molding machine, die-cast machine, industrial machine, platen presses, aircraft hydraulic and pneumatic lines and others.

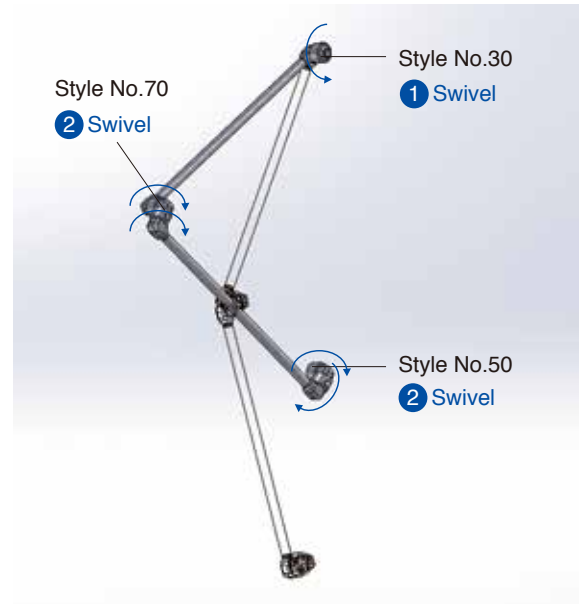

Style No.50-40-80 Combination

This combination allows adequate freedom of movement to compensate for any normal motion of a vessel, within operating range, as it rides in the water. The unit, when attached to barge or tanker manifold, is self-supporting and needs no tending during transfer operations. This combination is the principal design of TB-NIIGATA Marine Loading Arms.

Applications
Marine loading arms for crude oil, gasses, petroleum products, chemical and cryogenic products

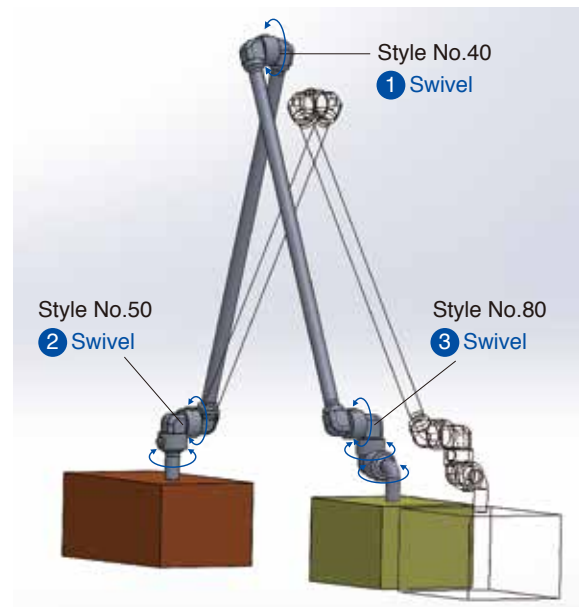

Style No.70-40-80 Combination

This joint combination smoothly absorbs all kinds of displacement in either of 3 axes (X, Y and Z) direction. Piping Direction: Vertical to Horizontal, Horizontal to vertical

Applications
Willow system



※Except for BD, BDR
As for BD, BDR, Please contact our sales representatives.

1 Working pressure	The pressure of the fluid flowing in the swivel joint shall be less than the value shown in "Appendix 1 Maximum Working Pressure".When manufacturing specification is supplied, the pressure shall be less than the shown value in the specification.
2 Style	The ball bearing part of the swivel joint is fabricated with high precision. The movement of the piping is accordingly limited in swivel direction.
3 Lubrication	<p>(1) Ball bearing part and sealing part must always be coated with lubrication grease to maintain smooth rotation of the swivel joint as well as to maintain perfect sealing function.</p> <p>(2) The swivel joint is injected with grease prior to shipment.</p> <p>(3) Frequency of lubrication In case of normal use swivel joint must be lubricated under maintenance. In case it is continuously rotated or used at high temperature, the swivel joint shall be periodically inspected for lubrication and supplied with grease if necessary.</p> <p>i) Remove the ball retainer plug of the swivel joint and visually check for change in color, hardening, deterioration and decrease of grease. Supply grease when at least one of above changes is recognized.</p> <p>ii) Guideline of inspection frequency (lubrication frequency) Recommendation: for use in continuous rotation: every three months for use at high temperature: every month Please establish the inspection frequency depending on the actual usage.</p> <p>iii) Supply grease according to "8. (6) Supply of grease".</p>
4 Packing	During long use of a swivel joint sealing function of the packing is gradually degraded to cause a small leak showing exudation or drip. The life of the packing finishes at this point and shall be replaced with a new one. Depending on circumstances the whole swivel joint must be replaced.
5 Rotation	Swivel joint is not rotary joint and is therefore not suitable to be rotated continuously. However, it may be rotated under non-severe conditions.
6 Moment Load	The moment load is one of the important matter that influences the life of the Swivel Joints. Also even the influence by the vibration etc. at the time of the misalignment, operation of piping think by the distance from the bearing of the weight thing and joint that are attached to piping and please pay attention sufficient on the occasion of the design.
7 Storage and initial use	In case of handling of solidifying liquid, the swivel joint shall not be rotated if it has already been solidified. Otherwise the solid may be dragged in and damage the packing which may cause degradation of the seal. Packing chamber of the swivel joint shall be fully cleaned not to keep solid residue inside.

8 Disassembly and reassembly

Disassembly

(1) Removal of ball retainer plug

- i) In case of screw type ball retainer plug, pull out cotter pin or wire, and then remove ball retainer plug and O-ring by using spanner or flathead screwdriver.
- ii) In case of snap ring type ball retainer plug, remove the snap ring by using plier and then take out ball retainer plug by picking at the center of ball retainer plug with a scriber etc. and tilting the joint slightly.

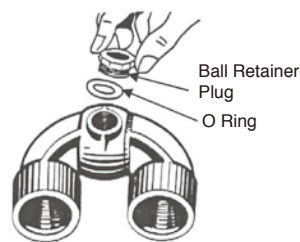

(2) Removal of ball

Make the holes of ball retainer plug upside down and rotate swing to let balls inside roll out. When it is difficult to rotate the swing, then rotate the coupling instead to take out the balls. If the swivel joint is hard to rotate, pour white gasoline etc. to loosen the tightened part.

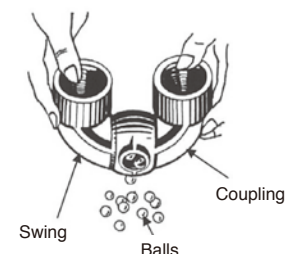

Danger When white gasoline etc. is applied, make sufficient ventilation and take enough care not to cause fire.

(3) Disassembly

After taking out all balls swivel joint can be separated to coupling and swing.

Caution Take care not to damage ball race and sealing surface of swivel joint.

(4) Removal of packing

Caution Avoid using scriber or similar tools to remove packing. If sealing surface of swivel joint is even slightly damaged, it may cause leakage.

(5) Removal of grease retainer ring and dust seal

Caution Take care not to damage sealing surface of swivel joint.

Inspection of removed parts

(1) Oil, dirt and attachment on the removed parts must be cleaned using suitable cleaner.

Danger Make sufficient ventilation when cleaner is used.

Caution Take care not to damage sealing surface and ball race surface.

(2) Ball race and sealing surface

Inspect ball race for crack, brine ling, corrosion etc. Very small defect may be removed using fine (more than #600 grade) sandpaper.

If the defect is hard to remove with sandpaper, that whole swivel joint shall be replaced.

Reassembly

When swivel joint is reassembled after disassembly and inspection, all parts except for the main body of swivel joint shall be replaced with new ones. Reassembly is to be made in the opposite order of disassembly. Take enough care not to include foreign particles attached on ball bearing part as well as on sealing part.

	Application	Grease
General use	Low pressure	Multi-purpose type
	High pressure Extra high pressure	Extreme pressure Multi-purpose type
	High temperature	Resist high temperature type
	Other than those above	Silicon grease, etc.

(1) Lubrication with grease

Apply suitable grease for the application thin and uniform on the packing, grease retainer ring, ball race and sealing surface.

(2) Mounting of grease retainer ring or dust seal

The grease retainer ring shall be fitted to the ring groove carefully making the direction of the lip as shown in the diagram.

The dust seal shall be adjusted with its length and then fitted in the ring groove.

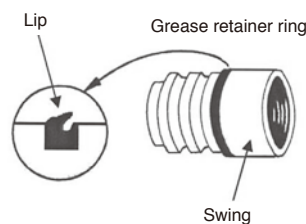

Caution Grease retainer ring shall not be stretched too much.

8 Disassembly and reassembly

(3) Insertion of packing

Be sure that outer ring (metal ring) is attached to the circumference of the packing. The outer ring is necessary to prevent the packing from protruding to the ball race side.

- i) A-Type When packing is inserted, make sure that the outer ring faces to the near side (ball race side).
- ii) B-Type The packing is allowed to face to either side.

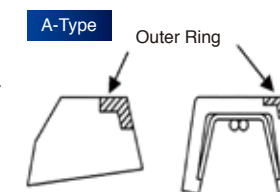

(4) Insertion of ball

- i) Firmly, fix the coupling. It makes it easier to mount the swing on the coupling.

Caution Avoid labored mounting or protrusion of grease retainer ring.

- ii) Insert swing so that coupling aligns with ball race of the swing.

Caution Avoid inserting the swing too far.

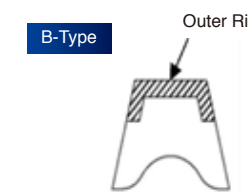

- iii) First prepare two balls for compressing the packing.

- iv) Insert a ball by tapping with a rod that makes it easier to insert the next ball.

Caution When tapping with a rod, take care not to damage the insertion hole.

- v) Necessary number of balls shall be surely inserted to fill each ball race full.

When the last ball is tapped with a rod, the first ball comes out.

Check whether all necessary balls are inserted in each ball race.

As for number of steel balls refer to "Appendix 2 Size and number of steel balls per swivel"

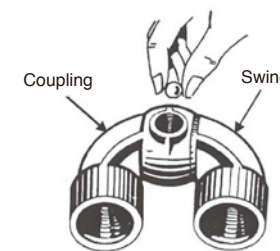

(5) Mounting of ball retainer plug

- i) Screwed type ball retainer plug
Fit O-ring first and then screw ball retainer plug into the body.
For high pressure swivel joint use a cotter pin or wire to prevent loosening.
- ii) Rubber ball retainer plug
Insert ball retainer plug and fit snap ring by using plier.

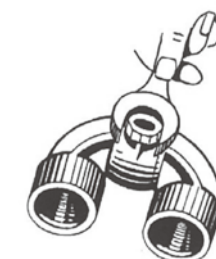

(6) Supply of grease

Caution Take care not to fill too much grease. If grease pressure remains, the packing may be deformed to cause leakage as well as disturbance of rotation.

9 Instructions for welding

Instructions for welding

Pay attention to the followings when swivel joint is welded to piping.

(1) Disassemble swivel joint before welding.

This is necessary to protect packing and grease retainer ring from excess heat and to prevent degradation of grease.

(2) Pipe and swivel joint body are tentatively mounted and welded to confirm neither eccentricity nor tilt exists and then open up full welding

- i) During welding bind up wet cloth etc. to prevent heating up of the ball race part over 80°C.
- ii) Take care not to damage machined surface of the swivel joint during welding work. Cover the finished surface not to be attached with spatter of welding.
- iii) After completion of welding clean the ball race part, packing, sealing surface of dust seal with cleaner.

Danger Make sufficient ventilation when cleaner is used.

10 Mounting position

To prevent leaking from the connection part with hose or pipe, please install swivel joint at the centering position.

TB-NIIGATA Weco Wing Union



Features

- Detachable pipes with an ease
- Compact and easily to replace seals

FIG.NO.	Color	Maximum pressure	Material	Size					
				Body Seal	1" 25A	1-1/2" 40A	2" 50A	3" 80A	4" 100A
602		6,000psi (41.4MPa)	S40C	●	●	●	●	●	—
			NBR						
1002		*10,000psi (69.0MPa)	S40C	—	—	●	●	●	●
			SCM435						
1502		15,000psi (103.4MPa)	S40C	—	—	●	●	—	—
			SCM435						
			NBR						

*Max pressure for FIG1002.5B is 7,500psi(51.7MPa)

How to use

Niigata Weco Wing Unions are commonly utilized as pipe connectors in drilling operations. They effectively address challenges related to the complex movement and twisting of high-pressure, long pipes by incorporating Swivel Joints in combination with the pipes.

- Usage
- Submarine & aboveground pipes of oil drilling machinery
 - Machinery for hot spring excavation
 - Pipelines for cementing

- Combination with Swivel Joint
- Steel Hose



FIG602								
Size	Dimensions (mm)					Weight (kg)		
	A	B	A	B LP	C		D LP	E Sch160
25	1	58.7	89.7	44.5	6.4	89.7	1.4	
40	1-1/2	81.0	123.8	65.1	6.4	119.1	4.1	
50	2	95.3	133.4	75.4	6.4	133.4	5.4	
80	3	119.0	158.8	105.6	9.5	144.5	9.5	
100	4	131.8	208.7	132.6	9.5	144.5	13.6	

FIG1002								
Size	Dimensions (mm)					Weight (kg)		
	A	B	A	B LP	C		D LP	E Sch160
50	2	95.0	133.4	75.4	6.4	127.8	5.8	
80	3	109.5	158.8	105.6	9.5	138.1	10.0	
100	4	124.0	208.7	132.6	9.5	144.5	14.5	
125	5	153.9	—	—	—	155.6	—	

*FIG1002 5B is only Butt welded & sealed with O rings.

Structure

- Standard screw thread end is Line Pipe Screw.
- We can produce Butt weld & other screw standard such as Rc & NPT.
- Please tell us about bevel measurement of pipes in case of welding.

*For further details, please contact us.

Line Pipe Screw End

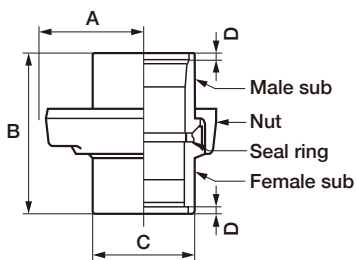

Butt Weld

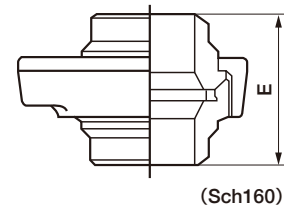

(Sch160)

TB-NIIGATA Ball joint

Features

Niigata ball joints in piping systems makes the following advantages.

- Ball joints allows for simultaneous rotation and tilt, enabling it to adapt to piping movements in multiple directions.
- The low-end thrust design extends the lifespan of your piping system.
- Experience cost savings as our ball joint reduces the number and weight of anchors and guides required.
- Maximize functionality in limited space with our compact and efficient pipe loops.
- Rest assured with our joint's ability to withstand shocks and vibrations, ensuring safety.
- Ball joint is meticulously designed for reliable operation and minimal maintenance in any usage.

Structure

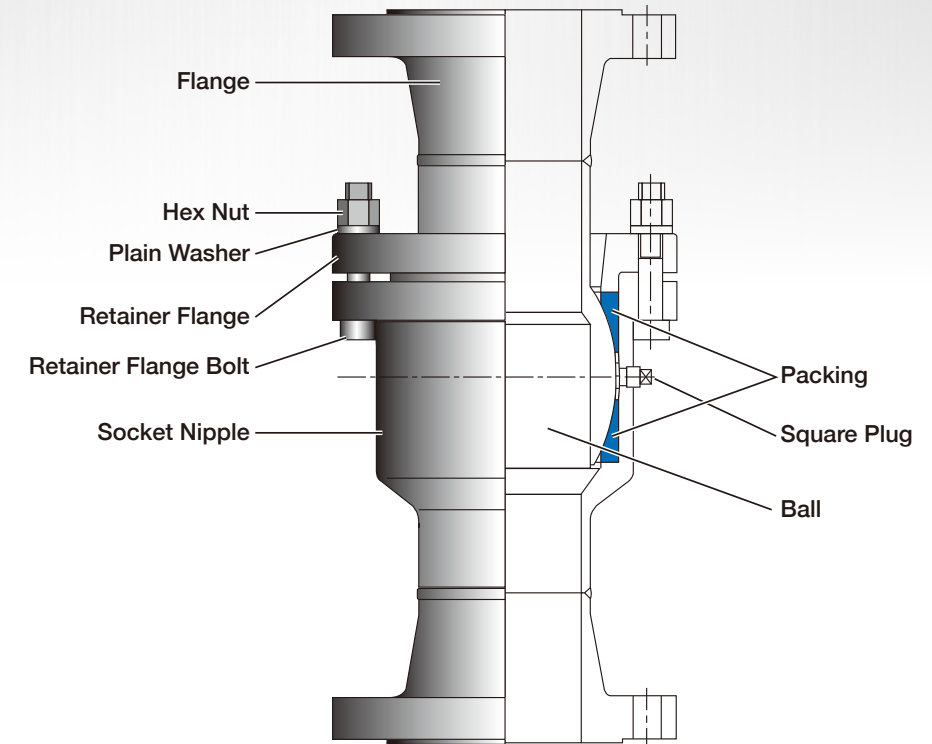

7.5° 7.5° Angle of movement ±7.5°

Material

Body	Carbon steel
Packing	Phenol, glass fiber Max. working temperature 200°C

Connection

Welded	Bevel end (Sch40)
Flange	JIS10K, JIS20K, JPI150 etc.,

