

Access

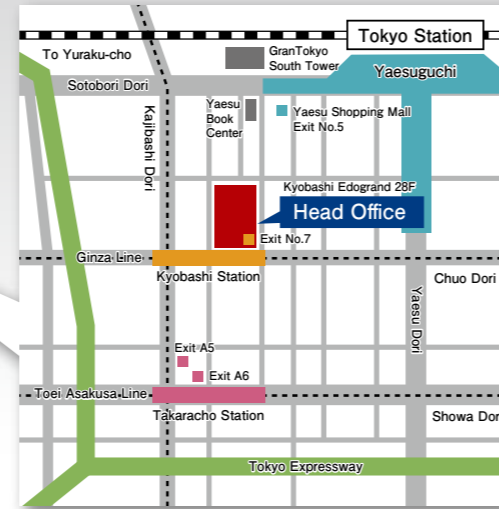

TB-NIIGATA

MARINE LOADING ARMS

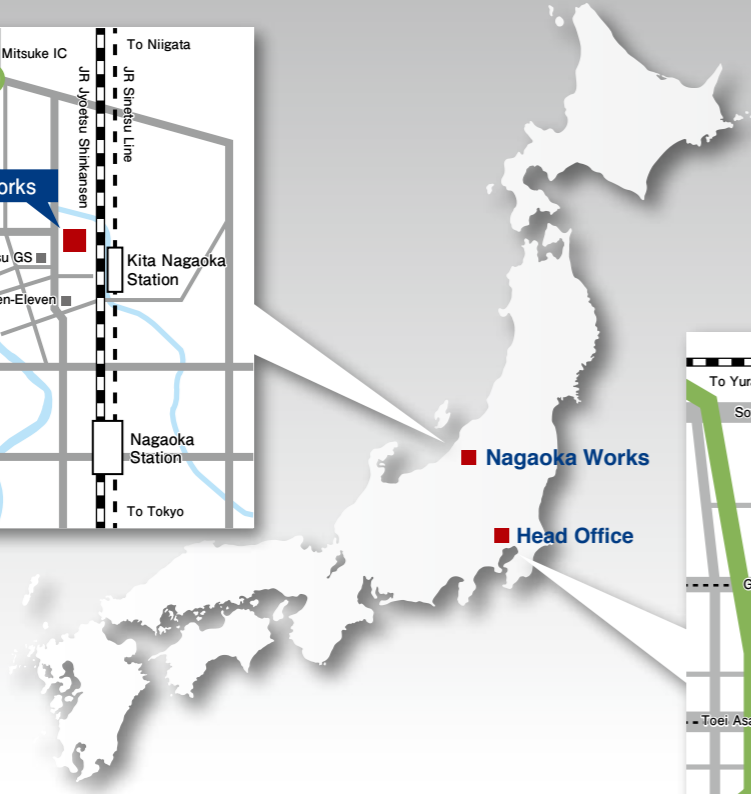
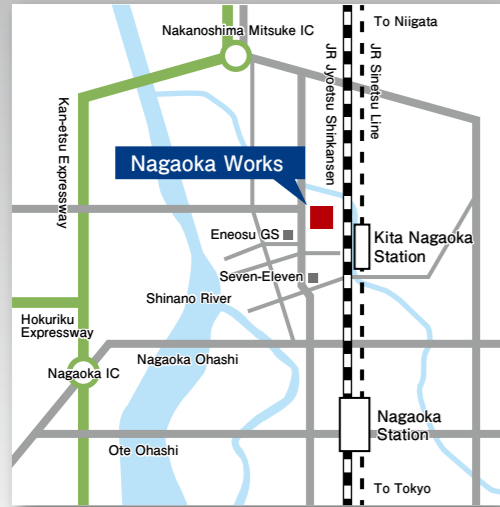
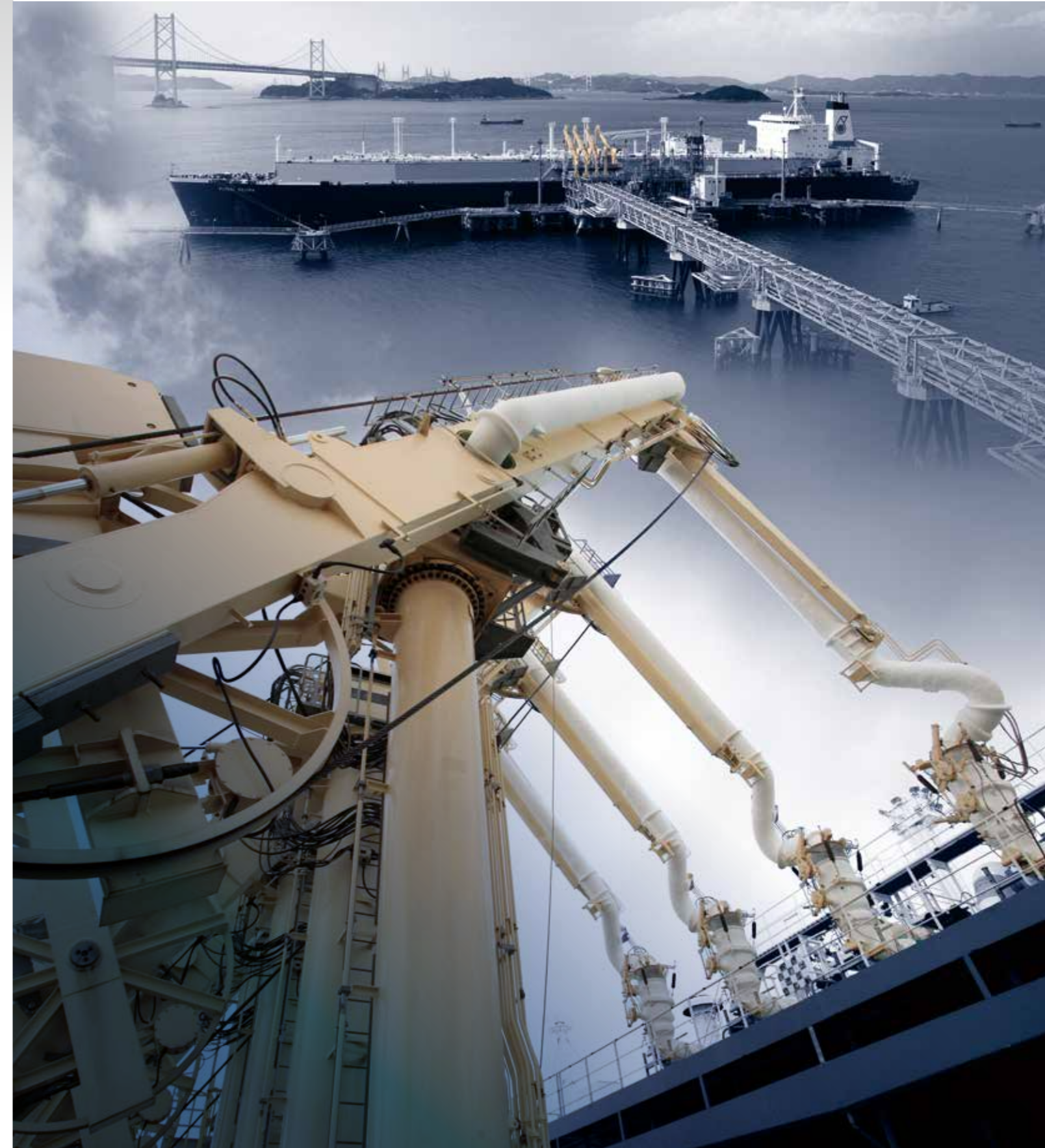

TB Global Technologies Ltd.

Notice : Tokyo Boeki Machinery Ltd. and Tokyo Boeki Engineering Ltd. merged on April 1, 2021 to become TB Global Technologies Ltd.

Head Office	28F KYOBASHI EDOGRAND, 2-2-1 Kyobashi, Chuo-ku, Tokyo, 104-0031, Japan TEL : +81-3-6841-8491 FAX : +81-3-6841-8450
Nagaoka Works	2-5-1 Jooka, Nagaoka City, Niigata, 940-0021, Japan TEL : +81-258-24-1650 FAX : +81-258-24-0000
Singapore Branch	2 Venture Drive #16-12, Vision Exchange, Singapore, 608526 TEL : +65-6909-2333 FAX : +65-6909-3474
Beijing Office	No.3 Dong San Huan Bei Lu, Chaoyang Discrit, Beijing, China 100027 Room 1014, Lucky Tower B TEL : +86-10-65516609 FAX : +86-10-65518229

<https://www.tbtech.co.jp>

TB-NIIGATA Marine Loading Arm Will Meet All Requirements for Oil and Gas Handling

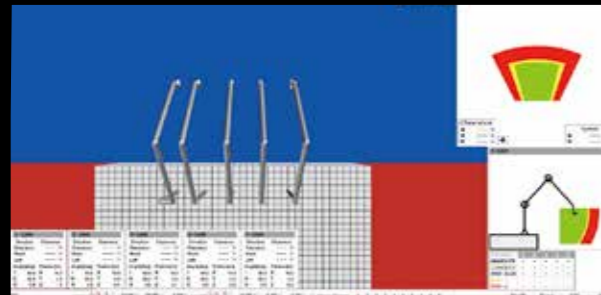

Position Monitoring System (PMS)



Emergency Release System (ERS)

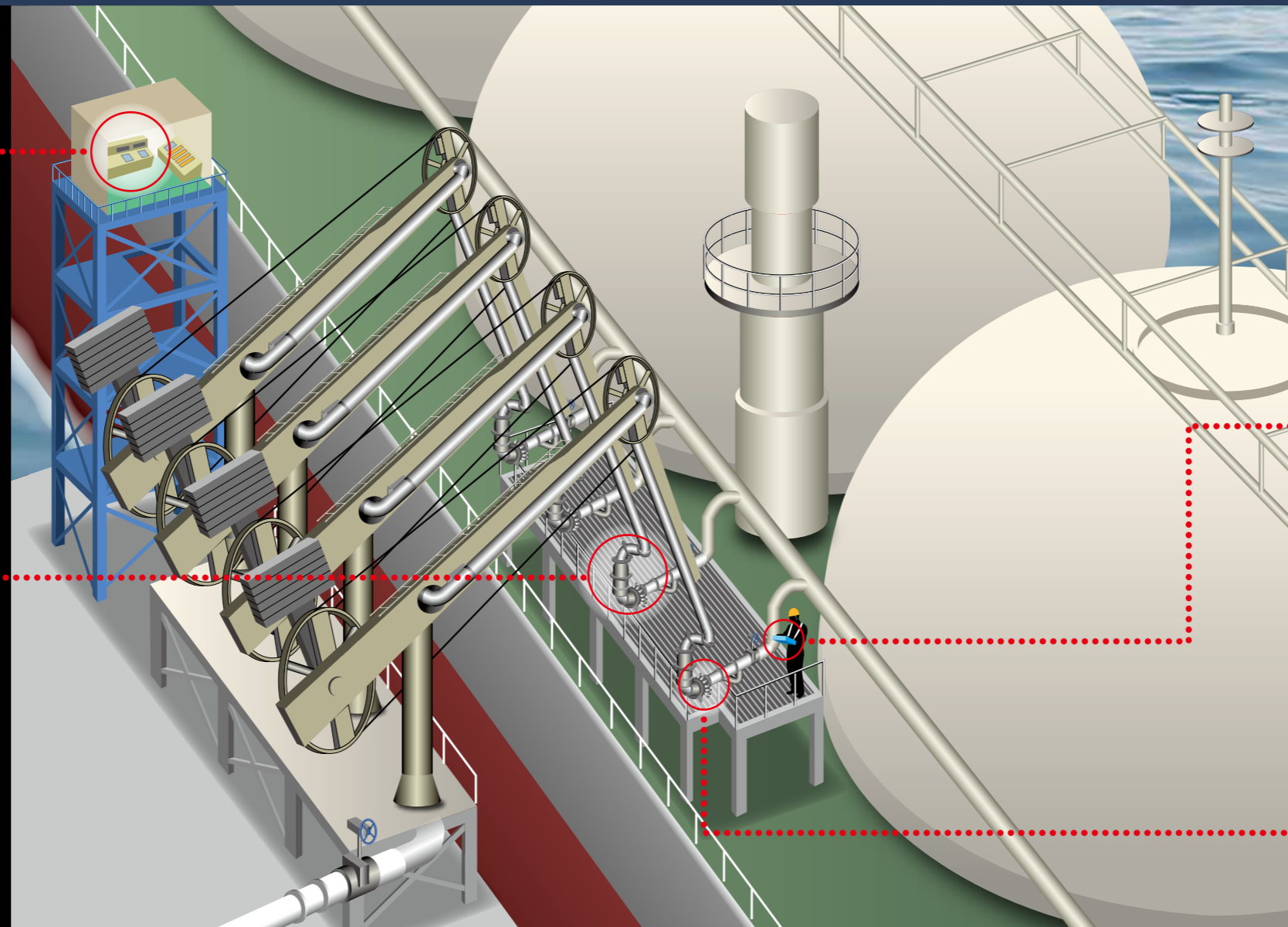

**TOTAL QUALITY...
WE MAKE ALL OF
THEM!**



Radio Control System



Hydraulic Quick Coupler (H-QCDC)

About Us

TB Global Technologies Ltd. (TBG) has been manufacturing loading arm systems since 1959 having half a century's experience where we always fulfill the needs of our customers for both marine and truck arms loading or unloading crude oil, LNG, or chemicals in any environmental condition.

Our long field of experience and high technical know-how assure best practice design, production, installation and after-sales service through our world wide network.

Features

Marine loading arm handling systems enable safer, faster and more secure economical loading operations in harsh conditions especially when compared with flexible hose loading systems.

Marine loading arms are designed for several tanker sizes from barges to the largest crude tankers (100~500,000DWT)

and are installed successfully at many terminals around the world.

TB-NIIGATA marine loading arms are equipped multi-ball races TB-NIIGATA swivel joints and specialized packing which permits safe loading operation without any product leakage.

TB-NIIGATA marine loading arms with the right combination of swivel joints (style 50-40-80) allow adequate freedom of movement to compensate for any motion of a vessel within the operating range.

Swivel joints and packing can be tailored to the fluid type to give the best product transfer performance of any kind of fluids or gases. Fluid types includes but are not limited to crude oil or petroleum products, cryogenic products, refrigerated LPG, ethylene or LNG (-162°C), elevated temperature products such as molten sulphur (120°C) or asphalt (180°C) and any many kinds of chemical products.

History

- 1902 Started NOC (NIPPON OIL.,LTD.)'s oil well machine maintenance business as a brunch factory of NIIGATA WORKS in Nagaoka city, Niigata prefecture.
- 1910 Became NIIGATA ENGINEERING's Nagaoka factory (current TB GLOBAL TECHNOLOGIES Nagaoka factory) due to the foundation of NIIGATA ENGINEERING CO.,LTD.
- 1959 Started a technical tie-up with CHIKSAN CORPORATION (USA).
- 1961 Started manufacturing Swivel Joints.
- 1962 Started manufacturing Loading Arms.
- 1968 Supplied first LNG loading arm to Tokyo Gas
- 1988 Completed retrofit work on 16" LNG arms with ERS.
- 1989 Total LNG loading arms supply exceeded 100 sets
- 1993 First automated arm supplied to OSAKA GAS.
- 1998 Obtained ISO9001.
- 2003 February 26th : NIIGATA LOADING SYSTEMS, LTD. founded.
- 2004 Presented about 5th generation LNG loading arm's new technologies at SOCIETY of INTERNATIONAL GAS TANKER & TERMINAL OPERATORS LTD.

- 2005 Supplied LNG loading arms fully manufactured in-house (Loading arm, ERS, H-QCDC) to SAKHALIN LNG. Total LNG loading arms supply exceeded 200 sets
- 2008 Developed an ERS with single cylinder for LNG service.
- 2013 Total LNG loading arms supply exceeded 300 sets
- 2015 NIIGATA LOADING SYSTEMS, LTD. changed its corporate name to TOKYO BOEKI ENGINEERING LTD.
- 2018 Opened the Singapore branch.
- 2019 Developed world's first loading arm for ship-to-shore transfer of liquefied hydrogen.
- 2020 Appointed as the "Companies Taking on the Zero-Emission Challenge" by the Ministry of Economy, Trade, and Industry in Japan
- 2021 TOKYO BOEKI MACHINERY LTD. and TOKYO BOEKI ENGINEERING LTD. merged to form TB GLOBAL TECHNOLOGIES LTD.

Basic Structure of Arm

Marine loading arm consists of 3 different types of swivel joints (6 plane of rotation)-Style 50,40 and 80.

The combination of these 3 types of swivel joints allows the arms to follow the movement of vessel in all planes smoothly and enables safe un/loading operation.

Style 50 swivel joint, located at the top of the riser, permits horizontal slewing and vertical movement of the arm assembly.

Style 40 swivel joint, connects inboard and outboard arms at the apex of the assembly and provides vertical rotation at the point of junction between in/outboard arms.

Style 80 swivel joint, the termination of the arm assembly, provides required flexibility in 3 planes where the arm connects to the barge or tanker manifold.

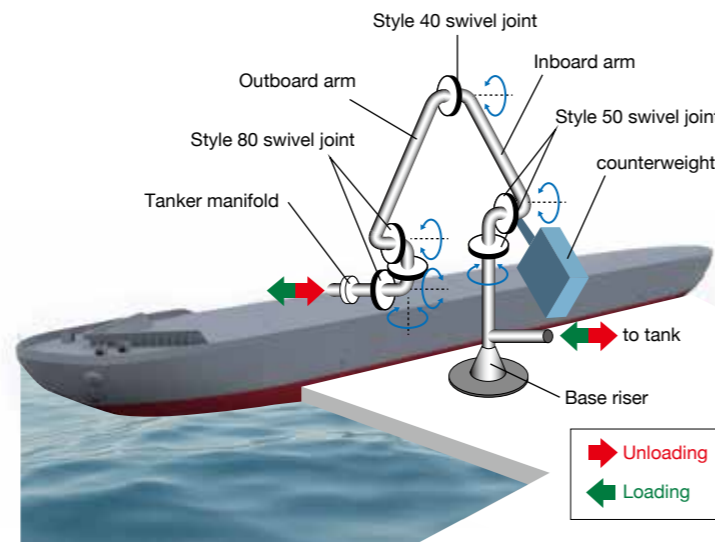

Swivel joint

The swivel joint, the key part of loading arm, with several machined ball-races allows 360-degree rotation and movement in one, two or three while under internal pressure and its performance and quality are highly evaluated by our customers since its development in 1920's.

TB-NIIGATA swivel joints with dual(triple)ball-races allows dispersion of load and its heat-hardened ball race and replaceable stainless steel Snap-in-Race used in joints enable high-resistance of thrust, radial and bending moment load.

The materials of joint body and packing are appropriately

chosen depending on the kinds of fluids handled, design pressure and temperature.

As the prevention of corrosion, the sealing part is stainless-overlaid.

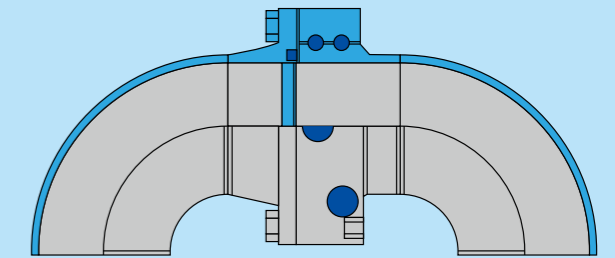

FBMA (Fully Balanced Marine Arm)



FBMA is the simplest and fully balanced loading arm having main counterweight and sub-counterweight.

It can be operated with only a few operators (manual type), and provide easy maintenance as well as overhaul.

design of the FBMA is available in 3"~12" (connection size), up to 14.5m long(sum of the length of in/outboard arms) for different kinds of products. Hydraulic operation is also available.

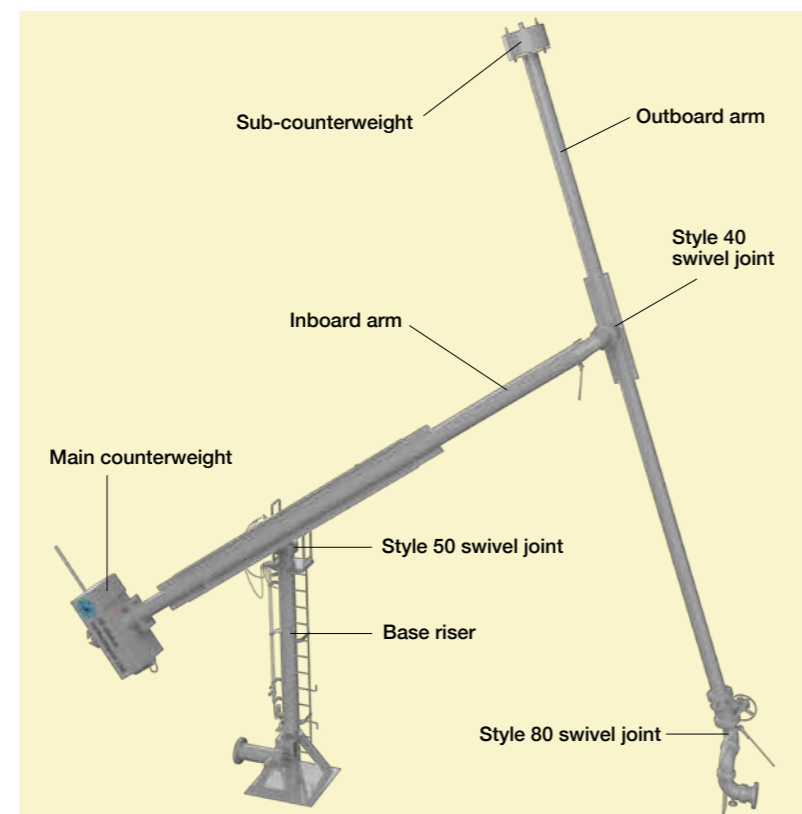

Size (end connection) : 3"~12"

Arm length : 8.5m~14.5m, up to 12.5m for 12"

Tanker size : 100~10,000DWT

Operation : Manual, Hydraulic

RCMA/RCMA-T/RCMA-S (Rotary Counterweighted Marine Arm/RCMA-Truss structure/RCMA-Suspended)



RCMA is fully balanced in all positions with the combination of rotary counterweight and a pantograph structure which balances both inboard and outboard arms simultaneously.

It is designed for smooth-operability and is used for larger diameter connections with a wide working range.

Both manual and hydraulic operation are available.

Connecting size is from 8"~24"(end connection), and the length of arm is available from 12.5m up to 30m.

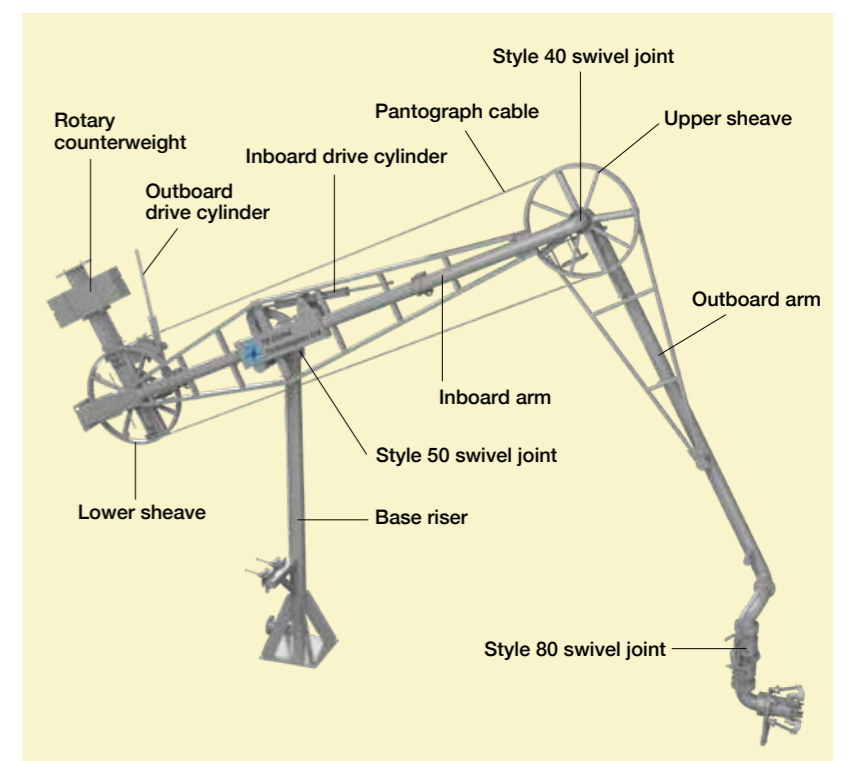

Size (end connection) : 8"~24"

Arm length : 12.5m~30m

Tanker size : 3,000DWT~500,000DWT

Operation : Manual, Hydraulic

Marine Loading Arms for Cryogenic Service

Cryogenic loading arms have been used for unloading/ loading of cryogenic products such as refrigerated ethylene(-104°C), LNG(-162°C) or liquid nitrogen(-196°C) since the first successful LNG loading to the tanker M.V "Methane Pioneer" in 1959. TB-NIIGATA cryogenic loading arms are available up to 20" and they include a hydraulic operating system as a standard equipment.

RCMA-S type loading arms, our main product, has a lot The most successful delivery and operations record in the world. Both hydraulic and manual operation are available and we offer optional equipment such as Emergency Release System(ERS), hydraulic coupler, radio controller, PMS alarming system and cartridge-type swivel joint to meet all the needs of our many customer.

Cryogenic swivel joint

Liquefied gases such as ethylene, natural gas and nitrogen are easily handled at very low temperature through the dual seal TB-NIIGATA swivel joints. Dual PTFE seals are tandemly arrayed with a structure proven to ensure high sealing performance. A water seal similar to packing is used to prevent ball-bearing damage ingress due to water or dust from outside. Low-temperature resistance stainless steel is used for the material of the swivel joint body.

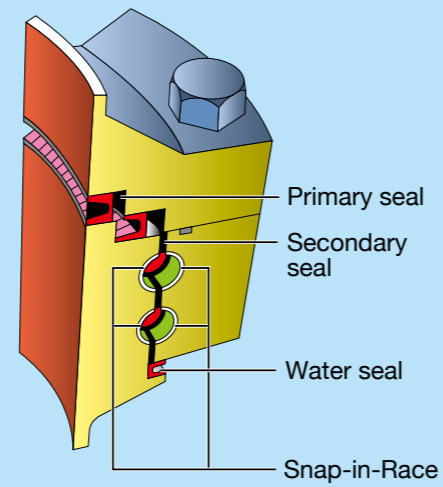

Snap-in-Race

All swivel joints used in TB-NIIGATA marine loading arms for cryogenic service employs Snap-in-Race which is replaceable ball-race. This specially hardened stainless steel ball-races withstand large load and ensure long-term usage. They are used for not only cryogenic swivel joints but for joints at ambient and elevated temperature.

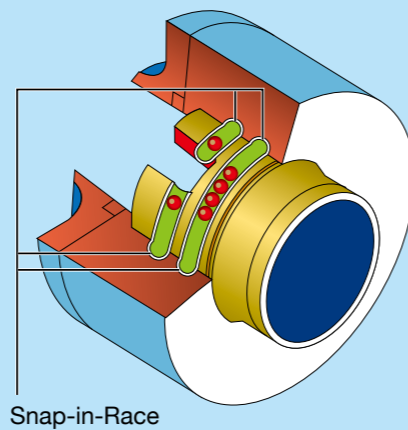

RCMA-S/DCMA-S For Export / Import Terminal (size : 16"~20")

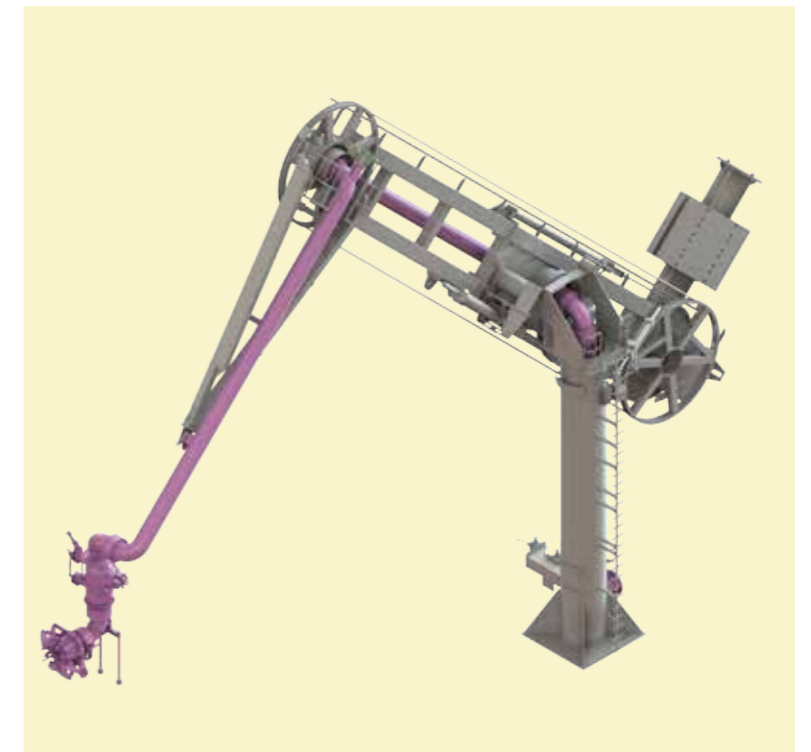

FBMA For Coastal Terminal (size : 6"~8")



Safety and Mobility ~ Satisfactory Product Lineup To Meet Every Need-1

Emergency Release System (ERS)

Emergency Release System(ERS) is the system that disconnects the loading arm from the tanker manifold within several seconds with no leakage in any emergency disconnect circumstance such as sudden and rapid movement of vessels due to gust, earthquake, seismic surges, or wave action.

This ERS system consists of the ERS unit installed integrally at style 80 swivel joint and the electrical/hydraulic equipment that controls the ERS unit.

TBG has successful ERS delivery records for different kinds of fluids and gases and since the first installation in 1982. LNG loading arms supplied for LNG export/import in and outside of Japan are equipped with this ERS unit.

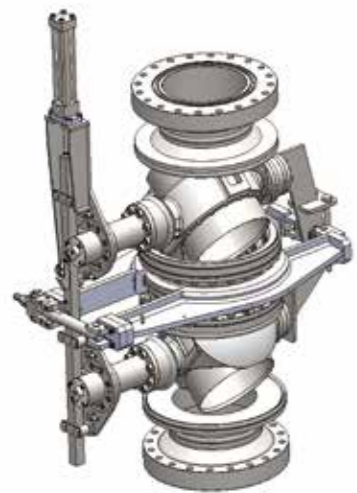

Separation begins

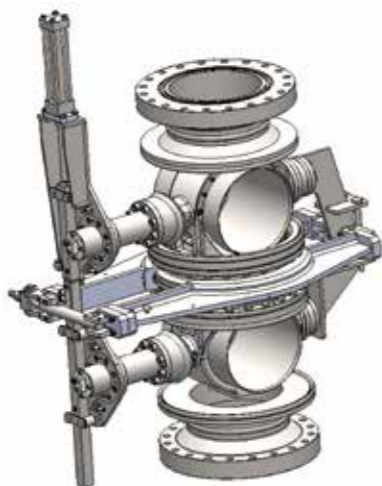

Two valves closed

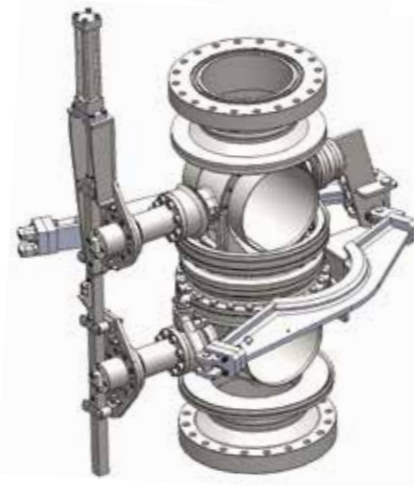

ERS opens
Separation complete

1 ERS valve separation begins



2 Two valves shut completely



3 ERS opens and completes separation



Position Monitoring System (PMS)

- (1) Position Monitoring System enables monitoring of the mooring location of the tanker connected with loading arms to assure un/loading operating condition.
- (2) By monitoring the mooring position of the tanker or the drifting speed constantly, this system allows you to correct the tanker position instantly.

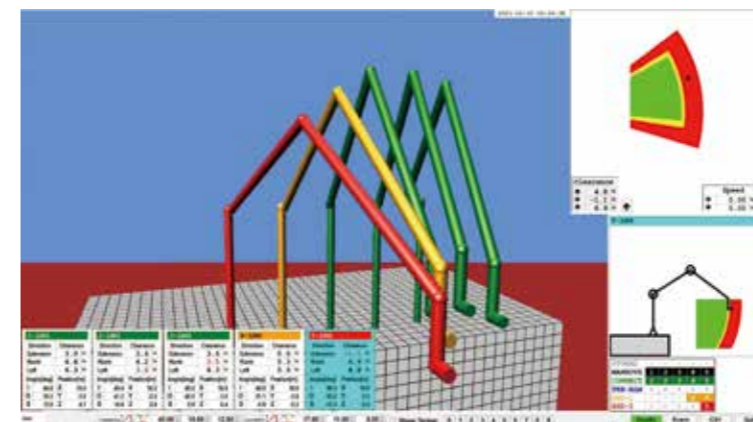
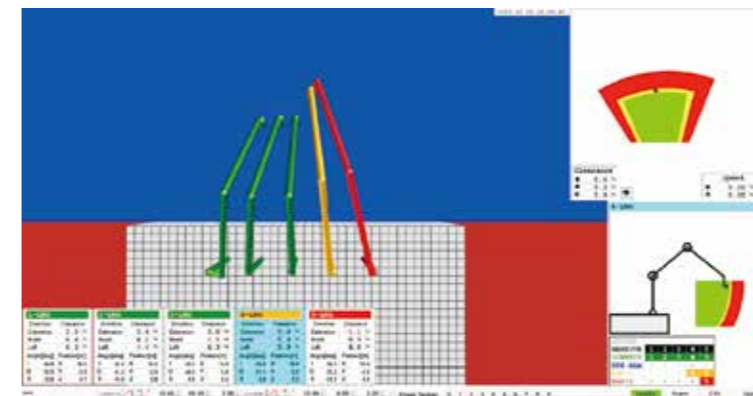

System outline

Based on the data from angle sensors installed on the loading arm, The PMS main unit calculates the location of the outer flange of the arm, the mooring position of the ship, drifting speed, or allowable working range. In an emergency situation, it alarms to prevent of arm damages.

These data from PMS main unit are sent to the PMS monitor located in the jetty control room or central monitoring room in the safty area, and the arm position and the tanker information (location·speed·distance) are shown on the display.

Installation advantage

The PMS monitor shows the position of each loading arm(stored·maneuvering·loading) or arm attitude instantaneously. It also monitors the mooring position of the ship and drifting speed constantly and enables to figure out the safety angles of each arms quantitatively.

The different kinds of real-time data from the angle sensors and alarming system for emergency allows situation to handle any contingencies and implement appropriate measures fast.

Radio Control System

Radio control system is developed for safe, assured and easy loading arm maneuvering.

[Features]

- (1) This compact and lightweight radio control transmitter allows one person operation.
- (2) This cordless control system also permits safe and easy loading arm selection and flanging operation in the tanker manifold area.

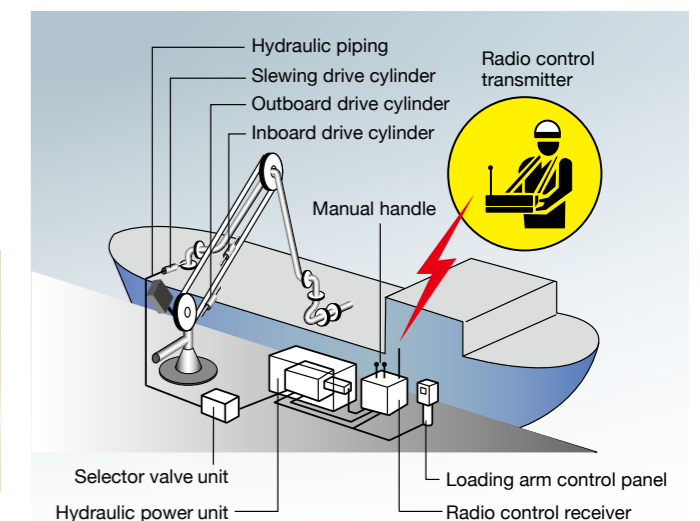

Safety and Mobility ~ Satisfactory product lineup to meet every need-2

Cryogenic service

(size : 16")

Hydraulic Quick Coupler (H-QCDC)

- (1) This hydraulic coupler is equipped on the end of the loading arm and enables quick, safe and assured connecting and disconnecting operation.
- (2) Combination usage with radio controller, one-man operating is capable.
- (3) H-QCDC units have installed on loading arms for large tanker to expedite arm dis/connecting operation.
- (4) TBG manufactures H-QCDC domestically to high quality standards.

Few loading arm makers have the technical knowledge to manufacturing H-QCDC, TB Global Technologies Ltd. provides all applications of service-design, manufacturing, installation and after sales service for H-QCDC.

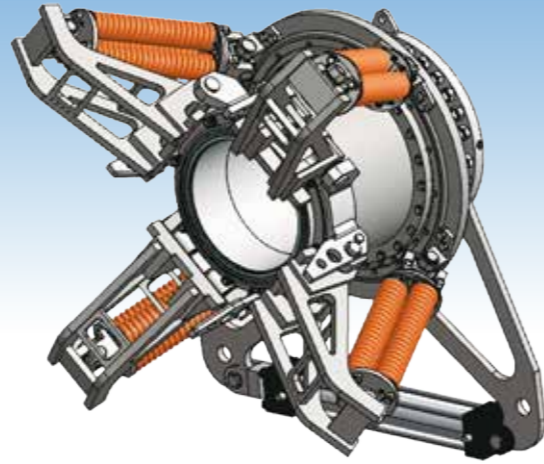

Ambient temperature service

(size : 10"~20")

Hydraulic Quick Coupler (H-QCDC)

The QCDC is installed at the end of the loading arm and allows fast, safe and accurate dis/connecting loading arm to the tanker manifold.

By using this quick coupler, it is not necessary to insert a flange gasket or to bolt the flange to the tanker manifold. The quick coupler is activated by hydraulic pressure and its flanging time requires only to complete a tight connection. After connecting coupler to the tanker manifold, the clamp is tightened mechanically, to assure the correct torque required for safe un/loading operation.

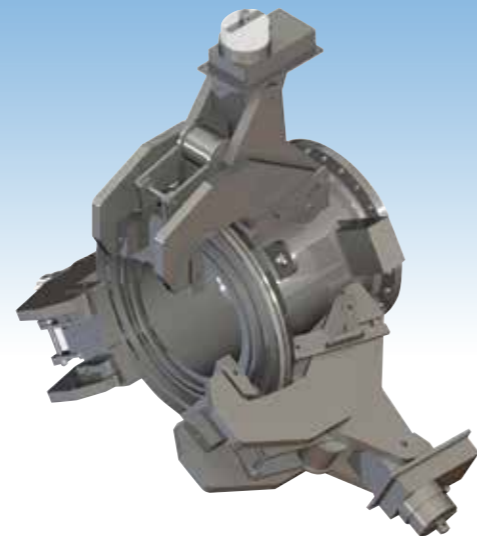

Manual Quick Coupler

The manual Quick coupler is installed at the end of the loading arm enabling an easy connection by rotating several clamps with the manual handle. It is unnecessary to insert the gasket or to bolt the flange to the manifold. The available size is from 6" up to 12" and it can be installed on the existing loading arms.



TB-NIIGATA marine loading arm for CNG service

- Designed based on our safe and reliable RC-S loading arm for cryogenic service.
- Assuring perfect balance with counter weight

Diameter	: 12"
Fluid	: HPNG
Design pressure	: 15MPa
Operating pressure	: 10MPa
Desing temperature	: -20 / 80°C

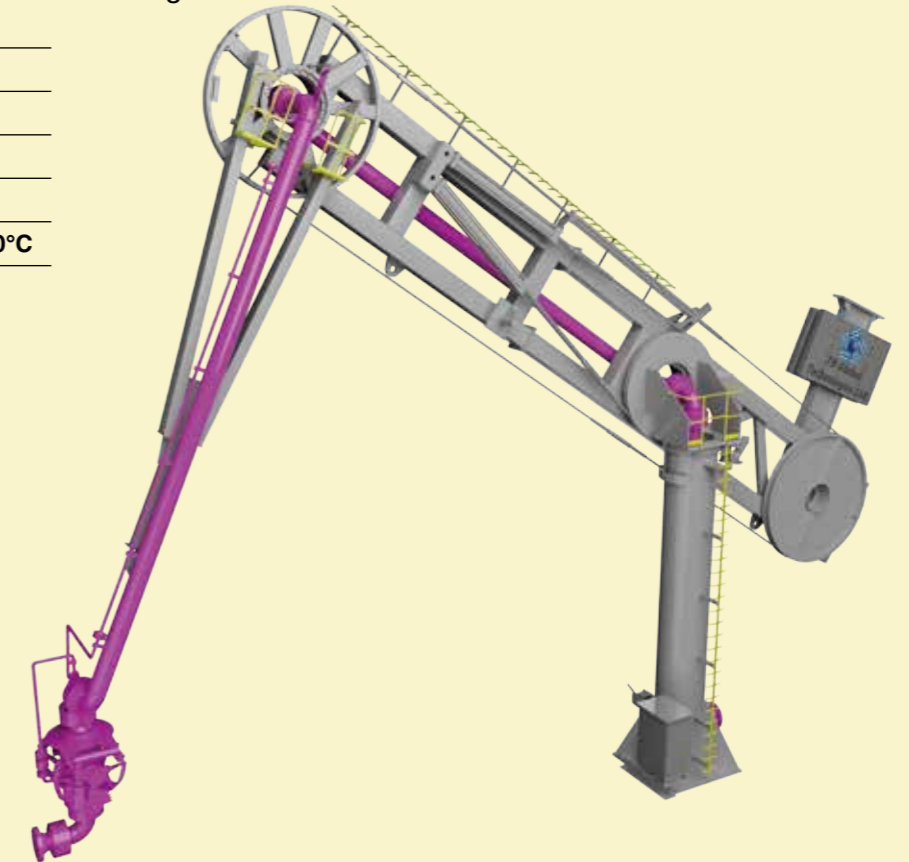

After-Sales Service



TB Global Technologies Ltd. provides quick and reliable after sales service worldwide in case of any troubles and needs of repair.

For safe and long-term usage of loading arms, our highly experienced personnel offer periodical inspection, maintenance and overhaul with TB-NIIGATA genuine spare parts.

All critical spare parts are stocked at TBG Nagaoka works and ready for timely shipment.