

CUSTOMER: _____	NIIGATA SWIVEL JOINT	SPECIFICATION NO. No.6CC711-043
LOCATION: _____		INQUIRY/ORDER NO. _____

INSTRUCTION MANUAL
(SANITARY)

 **TB Global Technologies Ltd.**

1	REVISED	July.11.'16	H.Isurugi	✍	✍	C.Tomii	
0	ORIGINAL	July.31.'12	A.Nagai	T.Natsui	✍	C.Tomii	
REV.	DESCRIPTION	DATE	APPR'D	CHK'D	CHK'D	PREP'D	CHK'D
ENGINEERING DEPARTMENT							RE'D SEC

Instruction Manual of Niigata • Sanitary Swivel Joints

1. Structure

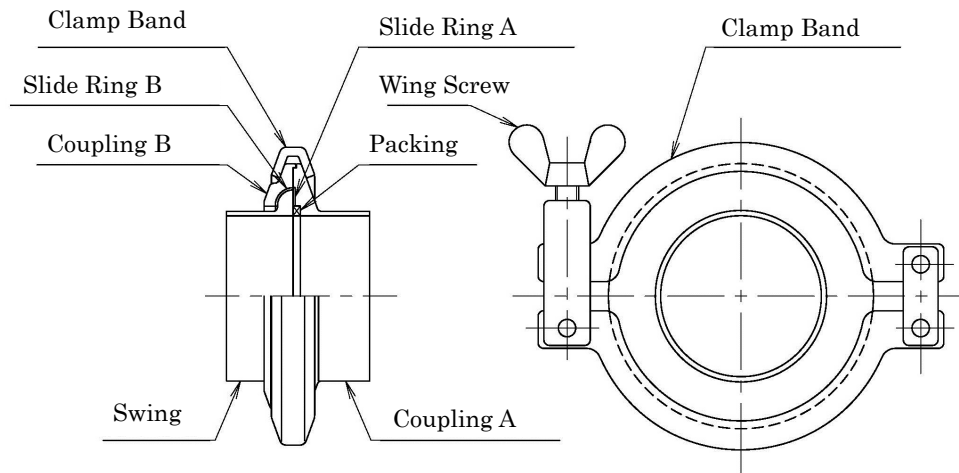

2. Disassembly

- (1) The joint can be disassembled, when the wing screw of the clamp band is loosed and the clamp band is removed.
- (2) Pay attention not to damage the packing seal face and the slide ring contact face when the joint is disassembled.

3. Assembly

- (1) Wash each part with a neutral detergent before assembly.
- (2) Confirm that there is no damage to the packing, the slide ring A, the slide ring B, the packing seal face, the slide ring contact face and the wing screw of the clamp band.
Exchange it to a new part, in the case that there is damage.
- (3) Assembly
Pay attention not to damage the packing seal face and the slide ring contact face when the joint is assembled.
 - ① Fit the packing and the slide ring A to the coupling A.
 - ② Fit the slide ring B between the swing and the coupling B.
Do not deform cut end of the slide ring with spreading more than necessary.
 - ③ Fit the coupling A and B, then set the clamp band.
Tighten firmly the wing screw of the clamp band with hand.
- (4) The joint should be rotated several times after assembly to confirm smooth movement.

⚠ 4. Instruction for use

- (1) At the time of the connection of the joint and the piping, centering of the joint and the piping must be conducted accurately.

The difference of centering may cause early leakage.

- (2) Disassemble the joint before welding when the joint and the piping are welded.

However, the coupling B must be kept fitted to the swing. Since the coupling B cannot be fitted after welding.

During welding, it is considered so that the packing seal face and the slide ring contact face are not damaged by heat affected.

Also be careful sufficiently not to damage the coupling B.

- (3) Exchange the packing, the slide ring A and the slide ring B when leakage occurred while the joint is used.

Also, confirm that there is no damage to the packing seal face and the slide ring contact face of the joint.

- (4) Grease for the lubrication is unnecessary, because Sanitary Swivel Joints are non-grease type joints.

- (5) Do not use negative pressure because it deforms the packing.